

Study Unit

Lubrication and Cooling Systems

By

Ed Abdo

Author Acknowledgment

Edward Abdo has been actively involved in the motorcycle and ATV industry for more than 25 years. He received factory training from Honda, Kawasaki, Suzuki, and Yamaha training schools. He has worked as a motorcycle technician, service manager, and Service/Parts department director.

After being a chief instructor for several years, Ed is now the Curriculum Development Manager for the Motorcycle Mechanics Institute in Phoenix, Arizona. He is also a contract instructor and administrator for American Honda's Motorcycle Service Education Department.

Preview

The importance of an engine's lubrication system and the lubricants used in motorcycle and ATV engines can't be overemphasized. If the proper lubricants are missing or the engine's lubrication system is operating improperly, the moving parts inside the engine can get hot enough to actually melt together. These internal engine components can score or even lock together in a matter of minutes! The buildup of heat, caused by friction, is one of an engine's worst enemies.

This study unit gives you an understanding of the types of lubricants and lubrication systems used in motorcycles and ATVs. It covers both the two-stroke and four-stroke engine designs. You'll learn how bearings, bushings, and seals help control and reduce friction. In addition, we'll discuss lubrication requirements for components of motorcycles and ATVs. You'll also learn about the specific cooling systems used on motorcycles and ATVs.

Most of what you'll learn about motorcycle engine lubrication systems applies to ATVs as well. From now on, we'll refer only to motorcycles in this study unit. Unless stated otherwise, you can assume that the information applies to both motorcycles and ATVs.

When you complete this study unit, you'll be able to

- Define the four key purposes of lubrication
- Describe the types of oil and how oil is classified
- Explain why bearings, bushings, and seals are needed in an engine
- Identify the different types of bearings used in motorcycles and ATVs
- State the purpose of both two- and four-stroke engine lubrication systems
- Identify the different types of lubrication systems used in both two- and four-stroke motorcycle engines
- Describe how cooling systems work and why they're used
- Identify the components of motorcycle cooling systems
- Identify the various specialty lubricants used in lubrication system maintenance

Contents

INTRODUCTION	1
LUBRICANTS AND LUBRICATION.	2
Cooling	
Cleaning	
Sealing	
Lubricating	
Types of Engine Oil	
Oil Classification	
Specialty Lubricants	
FRICION-REDUCING DEVICES	10
Ball Bearings	
Roller Bearings	
Tapered Roller Bearings	
Needle Bearings	
Plain Bearings	
Bushings	
Seals	
TWO-STROKE ENGINE LUBRICATION	15
Premixed Fuel and Oil	
Oil Injection	
Transmission Lubrication	
FOUR-STROKE ENGINE LUBRICATION	22
Dry-Sump Lubrication	
Wet-Sump Lubrication	
Oil Pumps	
Rotor-Type Oil Pumps	
Oil Pressure Relief Valve	
Oil Filters	
Oil Bypass Valve	
Oil Passages	
COOLING SYSTEMS	31
Internal-Oil Cooling	
Air Cooling	
Liquid Cooling	

LUBRICATION SYSTEM MAINTENANCE	40
Two-Stroke Engine	
Two-Stroke Transmission and Clutch	
Four-Stroke Engine, Transmission, and Clutch	
Other Components	
ROAD TEST ANSWERS	43
EXAMINATION	45

Lubrication and Cooling Systems

INTRODUCTION

Both two-stroke and four-stroke engines used in motorcycles have many moving internal parts that are machined to extremely close tolerances. To the naked eye, these parts have a very smooth, fine finish to optimize wear inside the engine. However, if you were to look at these same parts under a microscope, you would see that these seemingly smooth parts are actually quite rough! To reduce the friction that occurs if two or more of these surfaces make contact, it's necessary to maintain a thin layer of lubrication between them (Figure 1). A thin layer of lubricant between all internal engine parts effectively separates the parts from each other and provides a slight cushion for them to rest against. A lack of lubrication between these parts causes an immediate buildup of excessive heat, and in extreme cases causes the parts to melt together. When two or more parts inside an engine are hot enough to melt together in this manner, it's known as an *engine seizure*.

In addition to its role as a lubricant, oil inside an engine performs many other duties. The oil film that coats each of the internal parts keeps air and moisture from the parts and prevents the buildup of corrosion. Also, when used in the four-stroke engine, oil is constantly recirculated, carrying away contamination and trapping it in an oil filter. It's important to note that oil filters must be replaced or cleaned on a regular basis. Oil is also used to aid in the creation of seals of both two- and four-stroke engine parts that require additional sealing. Finally, oil helps to disperse the heat generated in high-temperature areas such as the piston, cylinder, transmission, and combustion chamber.

Although motorcycle engines built today are very efficient, they still waste a considerable amount of energy. Ideally, a 100% efficient engine would convert all of the heat energy it produces into mechanical energy. Unfortunately, there's a considerable amount of heat energy produced in engines that's unable to be converted, thus creating unwanted engine heat. It's the job of the lubricants and the engine lubrication and cooling systems to remove the unwanted heat, thus preventing engine damage.

Now, let's learn in greater detail about the lubricants, lubrication systems, and cooling systems used on the engines found on motorcycles and ATVs.

FIGURE 1—Engine parts that seem very smooth may actually be quite rough when viewed under magnification. Lubricants provide a cushion to prevent the rough edges from making contact with each other.

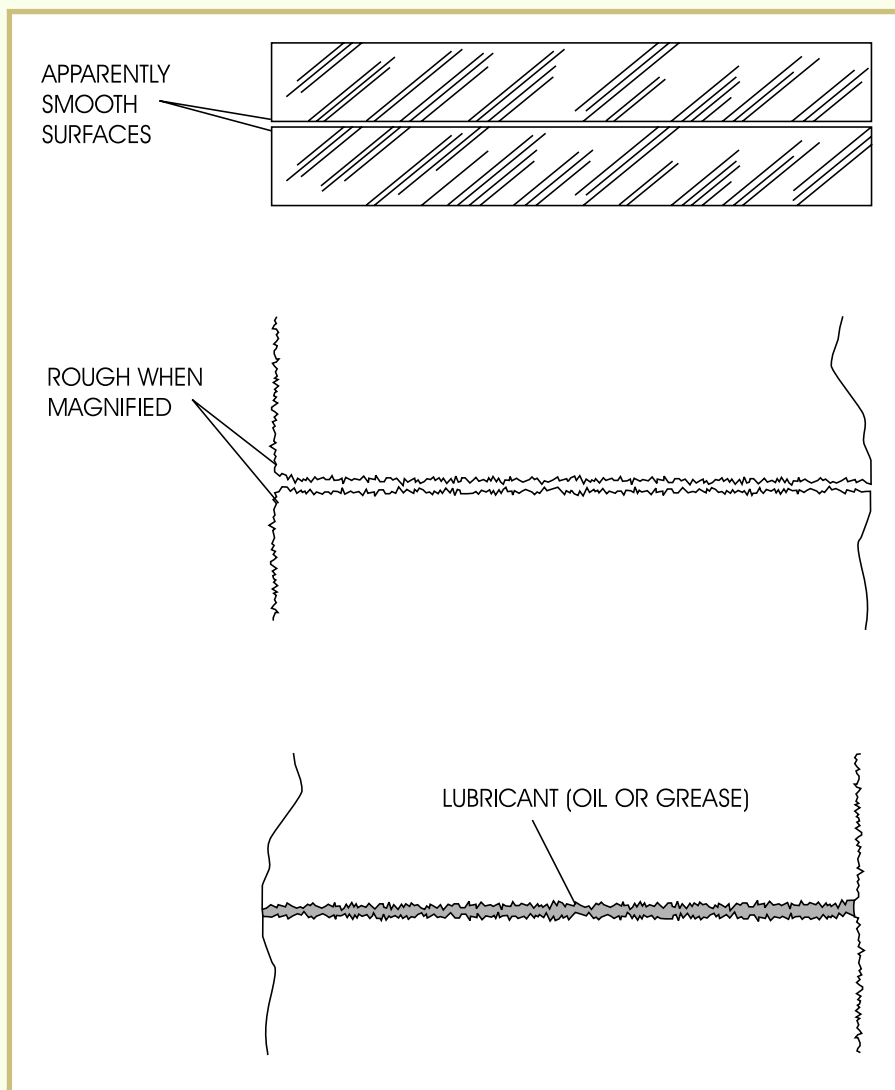

LUBRICANTS AND LUBRICATION

An engine has two main enemies: friction and heat. The main purpose of lubrication is to reduce friction. What's friction? *Friction* is the resistance to motion created when two surfaces move against each other, or when a moving surface moves against a stationary one. Friction can occur in many places in a motorcycle engine. Some of these places are on the

- Cylinder wall where the piston and piston rings rub
- Wrist pin and mating surfaces of the piston and connecting rod
- Crankshaft pin, bearing, and connecting rod
- Teeth of any gear inside the engine

- Camshaft lobes, tappets, valve guides, and valve stems (on four-stroke engines)

If these surfaces aren't protected by some form of lubrication, they'll quickly heat up and wear.

The great amount of heat created inside the engine by friction places a strain on vital engine components. To prevent these parts from overheating, motorcycle engines require quality lubricants. Lubricants and engine lubrication systems used on modern motorcycles have been greatly improved over the years due to the research done by motorcycle and lubricant manufacturers. The useful life of an engine without proper lubrication might be measured in minutes; the service life of a properly lubricated engine can be many years!

Lubrication serves four key purposes, which we'll describe in the following sections. When used properly, a lubricant will

- Cool
- Clean
- Seal
- Reduce friction

Cooling

When oil in the engine flows through oil passageways, it helps cool the internal engine components by absorbing heat away from the metal parts. The circulating hot oil is then returned to the engine's crankcase to be cooled.

Cleaning

While the oil is moving around and through the internal engine components, it's also cleaning the engine's parts. Combustion and normal wear and tear of engine parts produce tiny metallic particles and other contaminants. Today's motorcycle engine oils contain special additives that help hold these contaminants in suspension until they can be removed. The lubrication system removes contaminants as it passes oil through the engine's oil-filtering system. The oil filter system can't remove all the contaminants in the oil, so those remaining are removed by draining the engine oil. This is why oil turns darker in color after many hours of use.

Sealing

Another function of the engine oil is to help the piston rings seal in engine compression and combustion pressures. A thin oil film between the piston rings and cylinder wall is essential for the rings to seal properly. Oil between the piston ring groove and piston rings also aids in preventing combustion pressure leakage. Oil provides yet another sealing function for the engine seals located on sliding or rotating shafts.

Lubricating

It should now be clear that motorcycle engines consist of many internal component parts that contact each other as they move. As a result of this contact, a certain amount of friction and heat is always present. The main purpose of oil in a lubrication system is to help reduce friction by keeping a thin layer of oil between all of the engine parts. This thin film of oil helps to prevent excessive metal-to-metal contact and unwanted friction.

Remember, friction is the resistance to movement between two surfaces. A lubricant helps to reduce friction and the heat that friction produces. Lubricants thus reduce engine component wear.

Types of Engine Oil

In today's high-revving motorcycle engines, selecting a suitable lubricating oil is very important. Motorcycle and oil manufacturers have worked hard to develop oils that meet and even exceed the high demands of motorcycle engines. There are three basic types of oils used in the modern motorcycle.

Petroleum-Based Oils

The first type of oil is a standard *mineral-based oil*, also known as *petroleum-based oil*. Petroleum-based oil starts out as crude oil, located in large underground pools all over the world. After this oil is removed from the ground, it's heated in a process known as *fractional distillation*. This process separates the needed lubricating oil from other elements within the crude oil. The oil is then blended with other additives to create the desired oil viscosity. *Viscosity* refers to the measure of a fluid's resistance to flow. It's determined by the rate of oil flow under certain controlled conditions. A high-viscosity oil is thicker at room temperature than a low-viscosity oil.

Standard petroleum-based oils perform poorly without additives. *Additives* are selected and used in the manufacturing of oils to improve the oil's operating qualities. Additives don't change the basic charac-

teristics of oil, they just add new properties to it. Several additives are used in oil today; each is selected for a specific purpose. [Table 1](#) lists the types of commonly used additives and the characteristics they impart to oil. One example of an engine oil additive is sulfur, which is used to improve the oil's extreme-pressure properties. Another example is zinc, which is added to oil to increase its shear strength. Some desirable characteristics that result from the proper use of oil additives are a higher film strength, resistance to foaming of the oil, resistance to oxidation of the oil, and the ability to keep oil contaminants in suspension. One important and interesting fact about standard mineral-based oils is that the base oils themselves don't wear out, but the special additives do!

Table 1

IMPROVING AN OIL'S OPERATING QUALITIES

Additive	Characteristics Imparted to Oil
Oxidation inhibitor	Increased life, less sludge
Corrosion inhibitor	Protection against chemical attack
Viscosity index improver	Improved viscosity-temperature characteristics
Pour point depressant	Low-temperature fluidity
Oiliness agent	Increased load-carrying ability
Extreme-pressure additive	Lubrication under extreme pressures
Anti-foam agent	Resistance to foam
Detergent/dispersant	Ability to suspend contamination

Synthetic-Based Oils

Another type of oil is *synthetic-based oil*. Synthetic oils were developed during World War II, when petroleum products weren't widely available. Today's synthetic oils operate more efficiently and over a larger range of temperatures than standard mineral-based oils. When synthetic oils are manufactured, a variety of different types of synthetic additives are added to help increase the oil's effectiveness. Advantages to using synthetic-based oils include the ability to handle higher engine temperatures before breaking down, and less viscosity change with change in temperature. The main disadvantage to using a synthetic-based oil is that it may not be compatible with some petroleum-based oils. Synthetic-based oils are also more expensive than petroleum-based oils.

Petroleum/Synthetic Blended Oils

Blended oils are very popular today. They combine a petroleum base stock with synthetic additives, instead of petroleum additives. This combination greatly increases the quality of the oil. For this reason, blended oils are widely used in the engines of today's motorcycles.

Oil Classification

The internal-combustion engine has become more sophisticated and technologically advanced over the years, thus increasing the operating requirements of engine oil. As a result, two general automotive agencies were created to test, standardize, and classify lubricating oils (Figure 2). The first agency is the *American Petroleum Institute*, or *API*. The second agency is the *Society of Automotive Engineers*, or *SAE*. These agencies classify oil based on

- Manufacturer requirements regarding additives
- Intended use of the oil
- Viscosity ratings

FIGURE 2—All oils have labels showing a classification determined by the *American Petroleum Institute (API)* and the *Society of Automotive Engineers (SAE)*.



Letter Classification Codes

Oil classifications use a double-letter code to indicate their intended use and manufacturer requirements. Oils used in motorcycle internal-combustion engines have a code that begins with the letter *S*. The lowest-grade oil for use in the gasoline engine has a classification of *SA*. Although rarely used today, this type of oil is a straight petroleum-based oil containing no additives. This oil classification isn't recommended for use in any motorcycle. Today's highest-quality

and most-recommended oils are rated *SJ*. Oils rated *SE*, *SF*, *SG*, or *SH* are also recommended for use in many motorcycle engines. [Table 2](#) shows the various classifications used by the API. The API also classifies diesel engine oil. The letter code for diesel oil is *C*. Although you wouldn't use an oil designed for a diesel engine in a motorcycle, there are times when the same oil can be used for either engine. When this is the case, it's indicated on the API label.

Table 2

API OIL CLASSIFICATIONS	
Rating	Service Duties
SA	Mild conditions, no additives (base oil only)
SB	Medium conditions, uses anti-foaming and detergent additives
SC	Meets 1964 through 1967 automotive manufacturer requirements
SD	Meets 1968 through 1971 automotive manufacturer requirements
SE	Meets 1972 through 1979 automotive manufacturer requirements
SF	Meets 1980 through 1989 automotive manufacturer requirements
SG	Meets 1990 through 1993 automotive manufacturer requirements
SH	Meets 1994 through 1996 automotive manufacturer requirements
SJ	Meets 1996 through current automotive manufacturer requirements

It's important to understand which oil to use in a particular motorcycle engine. The motorcycle service manual and owner's manual contain the manufacturer's recommendation for oil.

Engine Oil Weight Classifications

Let's now discuss oil weight and how the Society of Automotive Engineers measures it. The weight of oil is a reference to its thickness, from extremely thin oils of 5 weight, up to 90- or 140-weight oils. It's important to understand that a lower-number weight, such as a 10-weight oil, is thinner than a higher-numbered oil, such as a 30-weight oil. The oil weight numbering system tells us that, all conditions being equal, a 10-weight oil flows at a faster rate than a 30-weight oil when poured through holes of the same size at the same temperature.

To determine the viscosity of an oil, it's poured through an orifice at a predetermined temperature. Two temperatures are used to test oil viscosity. For winter usage, oils are tested at 0 degrees Fahrenheit and

show the letter *W* after the number to indicate “winter.” All other oils are tested at a temperature of 210 degrees Fahrenheit or higher. Keep in mind that the weight numbers indicate the oil’s viscosity rating only. A higher-numbered oil, such as 50-weight oil, doesn’t indicate a better lubricant than say, a 10-weight oil. The weight of an oil has nothing to do with its quality; it’s a designation used for comparison purposes only.

So, what does this really mean? Different temperatures have a direct effect on oil viscosity. Oil tends to become thicker at lower temperatures, therefore, a lower weight number or a thinner oil should be used in cold weather conditions. Extremely hot temperatures require a higher weight number, or a heavier, thicker oil.

Multi-viscosity Oil

The majority of engine oils used in modern motorcycles have designation numbers such as 10W40 or 20W50. This type of oil is called *multi-viscosity oil*. These designations indicate oil viscosity that’s suitable for use under many different climatic and driving conditions. For example, a 10W40-rated oil gives proper lubrication in both cold and warm temperatures. The 10-weight rating indicates the oil will flow when the temperature is cold (recall that the *W* stands for winter test). Protection is also provided as the temperature increases, as indicated by the 40-weight rating.

Multi-viscosity oils contain additives that allow the oil to thicken at higher temperatures to improve the viscosity index. The *viscosity index* is the number used to indicate the consistency of the oil with changes of temperature. An oil labeled 10W30 is a 10-weight oil at 0 degrees Fahrenheit, but has the viscosity of a 30-weight oil at 210 degrees Fahrenheit. It’s important to note that oils such as these are specially designed; thus, combining a straight 10-weight oil and 40-weight oil doesn’t have the same effect as the factory-prepared 10W40 multi-viscosity oil.

The type or grade of lubricant best suited for proper maintenance of motorcycle engine components depends on many factors. Considerations include the type of motorcycle driving conditions; on- or off-road riding; hard and fast driving versus moderate-to-easy driving; and dry, wet, or extremely hot weather conditions. Motorcycle manufacturers recommend a certain type or grade oil or lubricant for each specific component need. It’s best to follow the manufacturer’s recommendations. If these recommendations aren’t readily available, check with the manufacturers themselves or ask your local motorcycle dealership. They can usually give advice that will help determine product suitability for the job at hand.

Specialty Lubricants

Now that you have a basic understanding of engine oils, let's briefly discuss other types of lubricants used on motorcycles. The type of *specialty lubricant* used depends on the component to be lubricated.

Grease

Grease is a lubricant that's suspended in gel. It's often used on non-engine-related components such as wheel bearings, swing arm bearings, and for the lubrication of steering-head bearings. Grease is designed for long-term lubrication.

Dry Lubricants

Dry lubricants are used to lubricate without attracting contaminants. These lubricants use an evaporating solvent as a carrier. Dry lubricants are often used on cables and areas that are in the open atmosphere.

Chain Lubricants

There are many different brands of *chain lubricants*. Just remember that there are two basic types of chain lubricants. Regular chain lubricants are used for standard drive chains; specialty lubricants are available specifically for O-ring chains. You'll learn more about chains used on motorcycles in a later study unit.

Other Lubricants

You'll use many other types of specialty lubricants, such as silicone spray, penetrating oils, and multipurpose lubricants, on various parts of motorcycles. These products are widely available and are used for everything from helping to loosen rusted nuts and bolts to lubricating squeaky parts.

Road Test 1

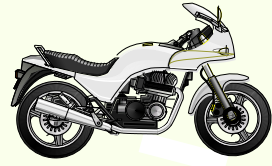

At the end of each section of *Lubrication and Cooling Systems*, you'll be asked to check your understanding of what you've just read by completing a "Road Test." Writing the answers to these questions will help you review what you've learned so far. Please complete *Road Test 1* now.

1. Name four purposes of oil lubrication.

2. The three basic types of engine oils used in motorcycles are _____, _____, and _____.
3. _____ is the process that separates lubricating oil from other elements in crude oil.
4. _____ is the term used to refer to the thickness of oil.
5. Standard petroleum-based oils perform poorly unless they have _____ blended into them.
6. The abbreviation *API* stands for _____.
7. The abbreviation *SAE* stands for _____.
8. What is a multi-viscosity oil?

9. What special type of lubricant is manufactured in gel form?

10. An oil that has the letter *W* after its number rating indicates that it was tested at what temperature?

Check your answers with those on page 43.

FRICION-REDUCING DEVICES

The purpose of *friction-reducing devices* in an engine or anywhere on a motorcycle is, as the name indicates, to reduce friction. These devices, called *bearings*, are also used to reduce free-play between engine shafts, allow for proper spacing, and support different types of loads. Bearings can use either a rolling motion or a sliding motion to reduce friction. Examples of bearings that use a rolling motion are

- Ball bearings
- Roller bearings

- Tapered roller bearings
- Needle bearings

Examples of bearings that use a sliding motion are

- Plain bearings
- Bushings

Keep in mind that the purpose of any bearing is to help reduce the buildup of friction between moving parts that are carrying a load.

Ball Bearings

Ball bearings are the most popular bearing used in motorcycle engines because they

- Provide the greatest amount of friction reduction
- Have the ability to handle both axial (side-to-side) and radial (rotating) loads

Ball bearings consist of spherical balls contained in a cage and held in place by inner and outer races ([Figure 3](#)). The cage ensures the balls don't touch one another. Ball bearings require very little lubrication. They're used to support transmission shafts in both the two- and four-stroke engine cases, allowing the shafts to rotate.

Roller Bearings

Roller bearings are similar in design to ball bearings, except they use cylindrical-shaped rollers instead of spherical balls ([Figure 3](#)). The roller bearing is capable of withstanding higher radial loads than the ball bearing due to its greater available surface contact area. Roller bearings are more commonly found in large-displacement motorcycle crankshafts.

Tapered Roller Bearings

[Figure 3](#) also shows a variation of the roller bearing, known as a *tapered roller bearing*. The diameter of each roller of a tapered roller bearing is larger at one end than at the other. Tapered roller bearings are normally used in pairs with opposing angles, such as in steering mechanisms.

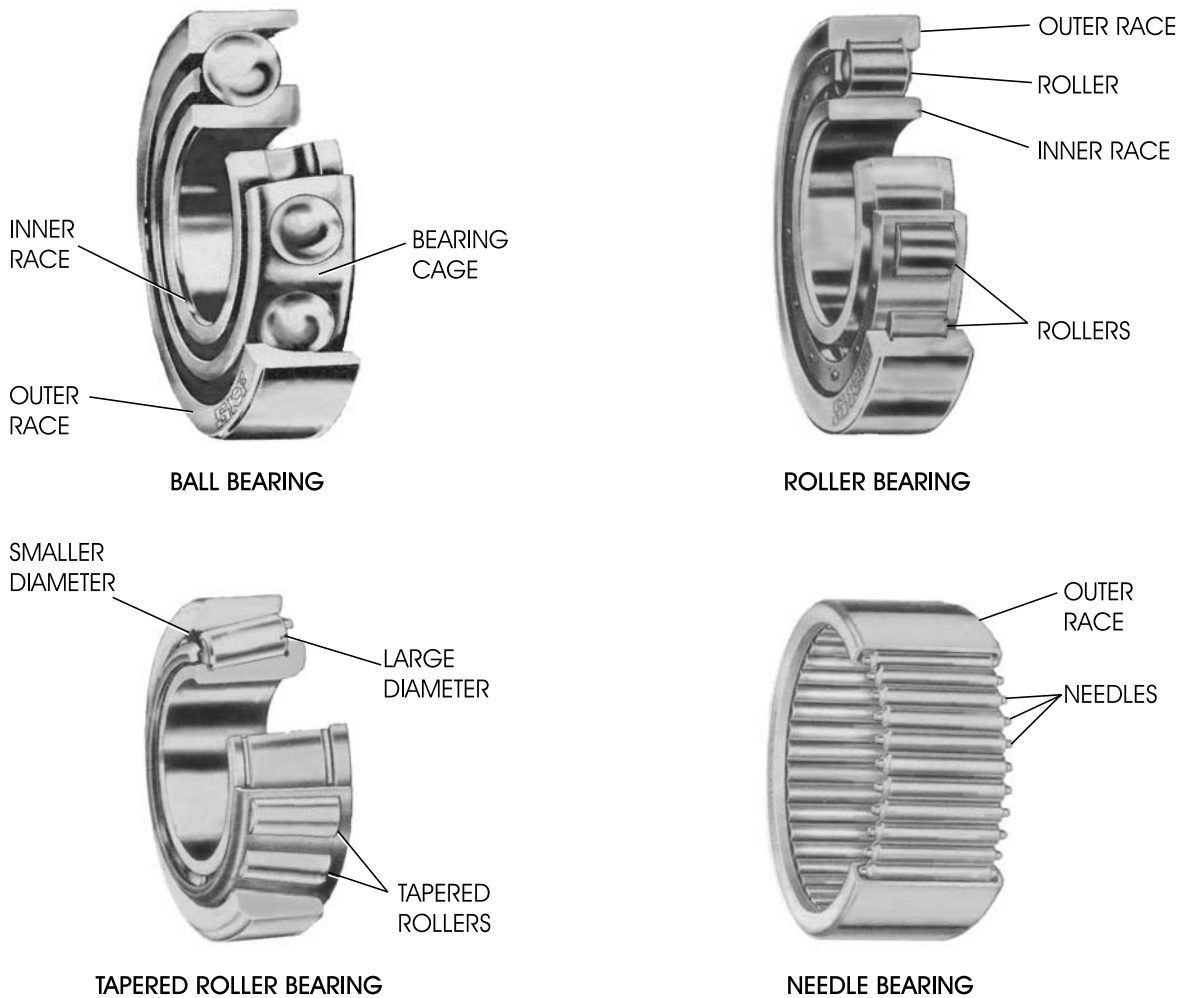

FIGURE 3—Bearings Commonly Found in Motorcycle Engines (Courtesy of SKF Industries, Inc. and The Torrington Company)

Needle Bearings

Needle bearings are yet another variation of the roller bearing (Figure 3). The needles or rollers of a needle bearing are usually several times longer than their diameters. Needle bearings normally have an attached cage, which keep the needles from making contact with one another. Needle bearings often have only an outer race. In this case, the needles make direct contact with the shaft surface they're supporting. Needle bearings can be found on some transmission shafts, swing arms, camshafts, and in two-stroke engine connecting rod small ends.

A key advantage of both the ball bearing and the roller bearing is that they can survive with minimal lubrication. However, if there's a total lack of lubrication, either bearing will be destroyed due to the extreme heat that occurs with friction.

Plain Bearings

Precision insert bearings, also known as *plain bearings*, are typically made in the shape of a cylindrical sleeve and are designed to withstand extremely heavy loads (Figure 4). They're used almost exclusively in the four-stroke engine. These bearings normally come in two separate pieces, but may also be of a one-piece design.

FIGURE 4—Plain bearings and bushings support large radial loads. (Copyright by American Honda Motor Co., Inc. and reprinted with permission)

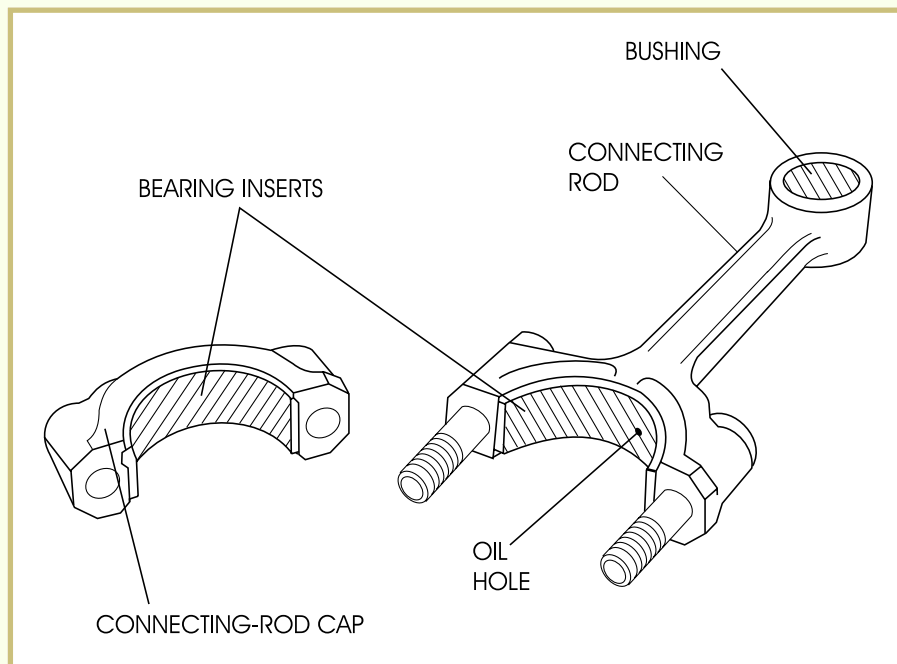

Plain bearings have a large surface area, which provides the ability to handle high radial loads. However, they don't reduce friction as efficiently as a ball bearing. Plain bearings can be found in two-piece connecting rod big ends, or they may be found as two-piece bearings supporting a crankshaft in the engine's crankcases.

Plain bearings require constant high oil pressure to produce a lubricating film known as *hydrodynamic lubrication*. This oil film, located between the rotating shaft and the bearing, is required at all times during engine operation to prevent unwanted metal-to-metal contact. The plain bearing receives the majority of its wear during the start phase of engine operation, due to the lack of lubrication at the time of engine start-up.

Bushings

Like plain bearings, the purpose of a *bushing* is to support large radial loads, and occasionally, axial loads. Bushings are cylindrical in design with a lining made of a soft alloy such as brass, aluminum, plastic, or silicone bronze (Figure 4). Most bushings are press-fit into place and are normally replaceable. A *press fit* is a force fit that's accomplished using a press. In contrast, a *push fit* is a force fit that's accomplished manually.

Seals

Although not used to reduce friction, *seals* are used on transmission shafts and other rotating shafts within a motorcycle engine to

- Prevent oil loss from the engine and bearings
- Keep contaminants from entering the engine and bearings
- Seal out atmospheric air, when necessary

There are many types of seals, as shown in Figure 5.

Seals are usually held in place by press or push fit. In most cases, the seal lip applies tension against the shaft by the use of a spring, which creates a predetermined amount of sealing pressure. The engine oil keeps the seal lubricated for durability.

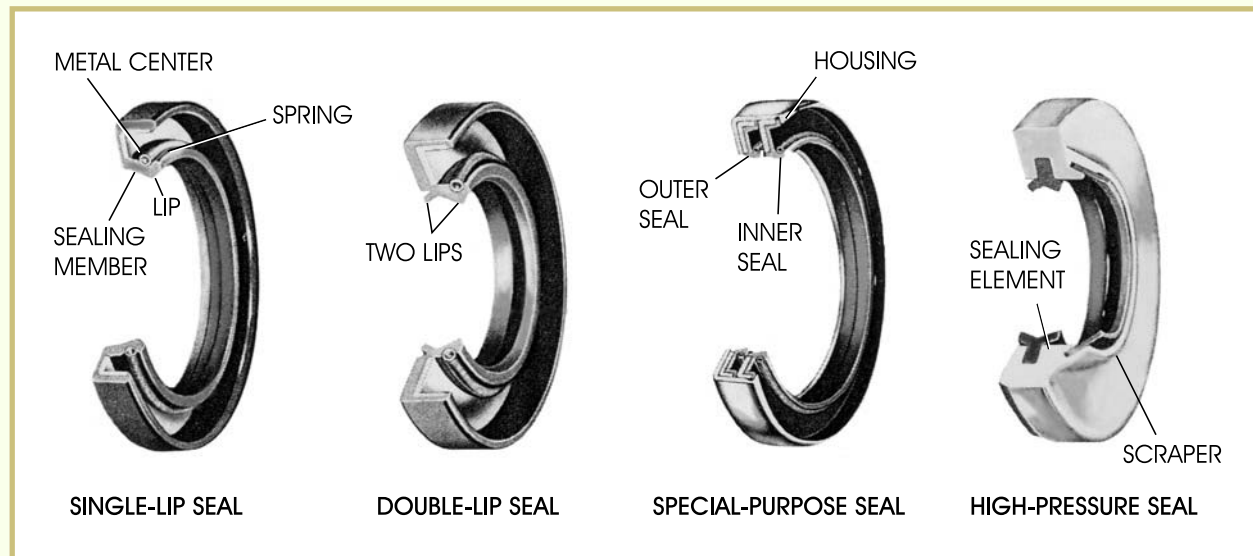

FIGURE 5—Seals are made in many designs.

Road Test 2



1. Explain the purpose of a bearing.

2. Name the four basic types of bearings, commonly used in motorcycle engines, that use a rolling motion.

3. The _____ bearing is similar in design to the ball bearing, but is capable of withstanding higher loads because it has more surface area.
4. Steering mechanisms often use a _____ bearing to help reduce friction.
5. The _____ bearing can come in either one piece or two pieces.
6. What's the purpose of a seal?

7. Which bearing requires high-pressure lubrication at all times?

8. Name two types of bearings that require very little lubrication to operate.

Check your answers with those on page 43.

TWO-STROKE ENGINE LUBRICATION

As mentioned in a previous study unit, the lubrication of a two-stroke engine is different from that of a four-stroke engine. In the two-stroke engine, lubrication is accomplished by mixing fuel with a recommended two-stroke oil, then introducing the mixture to the internal moving parts of the engine. When the oil-and-fuel mixture enters the engine, the oil lubricates the piston and other moving parts. The mixture also enters the combustion chamber, where it's ignited by a timed ignition spark. Because the oil doesn't burn as well as the fuel, much of it remains in the engine to lubricate the internal engine parts.

Another distinguishing fact about two-stroke lubrication systems is that all two-stroke motorcycle engines separate the transmission from the crankcase where the crankshaft, piston, and ring(s) are located. The oil used to lubricate the transmission is different from the oil used to lubricate the piston, piston rings, cylinder, and crankshaft. A standard multi-grade lubricant or a special blended transmission gear

oil is used to lubricate the transmission in a process known as an *oil bath splash*. As the gears rotate, they pick up the lubricant and splash the oil onto other moving components in the transmission.

Oils used to lubricate two-stroke engines are specially prepared and recommended by the manufacturers. They help reduce piston-to-cylinder wall scuffing and reduce excessive carbon buildup in the cylinder combustion chamber, exhaust ports, and exhaust systems. It's essential to combine the special two-stroke oil and fuel before the mixture enters the engine, to ensure that all of the internal engine components receive the correct amount of lubrication. The oil uses the fuel as a carrier to get into the engine, then separates itself from the fuel. Although it does eventually burn, the oil isn't designed to burn with the fuel in the combustion chamber, but to lubricate the moving parts of the engine.

Let's now examine the two methods used to provide two-stroke engine lubrication.

Premixed Fuel and Oil

The *premixed method of lubrication* in a two-stroke engine requires the use of a specified ratio of gasoline and oil mixed together in a recommended container. The container can be the fuel tank of the motorcycle, but it's usually recommended that this procedure be completed in a separate fuel container to ensure proper mixing. [Figure 6](#) shows that the fuel and oil have already been combined prior to entering the engine. It's important to always shake the mixture well before using it, to ensure that the oil and gas are completely mixed.

Use the following steps to determine how much oil to mix with the fuel to obtain the proper fuel-to-oil ratio.

1. Divide the number 128 (the number of ounces in a gallon of gas) by the manufacturer's recommended fuel-to-oil ratio.
2. Multiply the result of Step 1 by the number of gallons of gasoline to be used. The result is the number of *ounces* of oil you need to add to the gas.

As an example, let's determine how much oil must be added to 5 gallons of fuel when the manufacturer recommends a 40:1 fuel-to-oil ratio. Step 1: Divide 128 by 40. The result is 3.2, which is the number of ounces of oil that must be added to *each* gallon of fuel. Step 2: Multiply 3.2 by 5. The result is 16. Therefore, 16 *ounces* of oil must be added to 5 gallons of fuel.

The recommended ratio of fuel to oil may vary from 16:1 (16 parts of fuel to every one part of oil) to 50:1 (50 parts of fuel to one part of oil). Variations are based upon the manufacturer's recommendations and the brand of oil used. Many different brands of oil are available, each

with different lubrication qualities. Be sure to investigate each product carefully and choose one based on the manufacturer's recommendations. More importantly, choose one that best protects the two-stroke engine's moving parts.

FIGURE 6—With the premixed method of lubrication, the rider combines the fuel and oil manually, prior to the mixture entering the engine. (Copyright by American Honda Motor Co., Inc. and reprinted with permission)

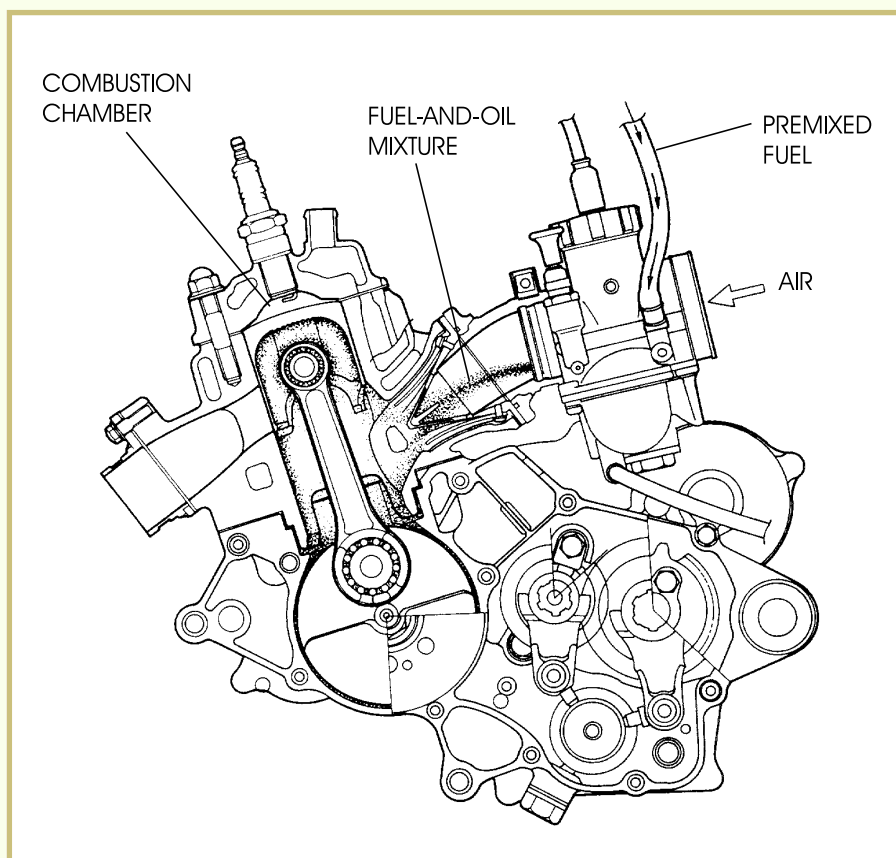

One disadvantage of premixing the fuel and oil is that there's no way to adjust the amount of oil entering the engine with the fuel as the engine operates. At slow engine speeds, the engine doesn't work as hard; thus the proportion of oil may be greater than required to lubricate the engine components. The result may be excessive oil in the engine. As the engine speed is increased, excess oil exits through the combustion chamber, causing exhaust smoke as the mixture burns. Excessive oil can also cause the spark plug to *foul*, or misfire. At higher engine speeds, on the other hand, the proportion of oil may not be adequate enough to supply sufficient lubrication needed to reduce friction. These are reasons why it's so important to use the recommended oils and oil ratios.

Oil Injection

The method of injecting oil into the engine, instead of premixing it with the fuel, requires the use of a pump. An oil pump measures and feeds the oil from a separate storage tank to all of the two-stroke engine's components that require lubrication (Figure 7). With an *oil injection system*, the mixing of oil and gas occurs automatically. The amount of oil pumped to the engine's components is regulated by increasing or decreasing the speed of the engine.

FIGURE 7—With the oil injection method of lubrication, the mixing of oil and gas occurs automatically, assisted by an oil pump that feeds the oil from a storage tank.

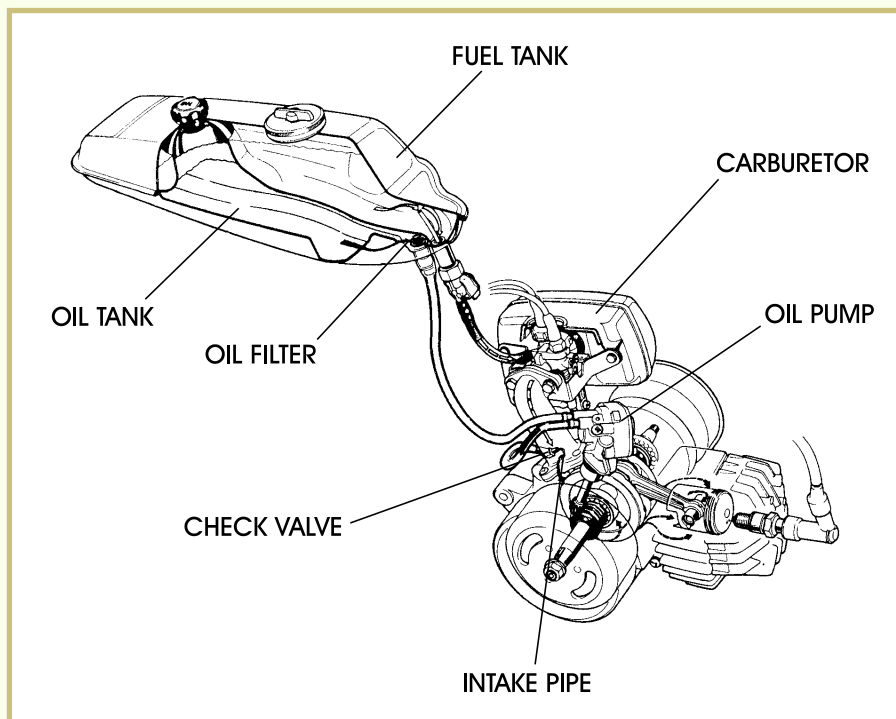

Oil injection systems offer several advantages. Not only does the motorcycle rider not have to mix the oil with the gas, but perhaps more importantly, oil is supplied to the engine's internal components in the correct amount required to provide the best protection at different engine speeds. Most two-stroke engines using oil injection have internal oil passages to help feed more oil to those internal engine components that require extra lubrication. Examples of these areas are the bearing of the connecting rod big end and the crankshaft main bearings. A smaller quantity of oil is fed to those engine components requiring less oil. Examples include the piston wrist pin and rings.

Oil injection systems can reduce the total oil consumption of the engine because the oil is used only as needed, based on the engine's operating speed. As the engine speed increases, more oil is injected into the engine; at slower speeds, less oil is injected. This helps reduce oil consumption, spark plug fouling, and excessive smoke, and can help to increase the engine's life. More importantly, oil injection pump systems supply the proper amount of oil to the moving parts, even when

the carburetor slide is suddenly closed down and the engine speed remains high. This prevents engine seizure that would otherwise be caused by lack of lubrication. Remember, with the premixed method, oil must enter the two-stroke engine with the fuel. When the carburetor slide is closed on deceleration, the oil supply to the engine's internal components is drastically reduced. An oil injection system, on the other hand, doesn't have this effect.

A cable connecting the throttle housing to the oil pump controls oil pump output (Figure 8). Turning the throttle twist grip causes the carburetor throttle valve and oil pump to open. This allows the oil pump to automatically increase its oil output in proportion to the air/fuel supply from the carburetor. Most two-stroke engines synchronize the oil pump to the carburetor throttle valve. That is, the pump is set to supply a quantity of oil to the engine in direct relation to the quantity of air/fuel mixture supplied to the engine. As a general rule, the pump lever to which the cable is connected is adjusted to move to a predetermined point when the throttle is wide open and to return to its original position when the throttle is closed.

FIGURE 8—The throttle cable controls the oil-injected two-stroke engine oil pump. (Copyright by American Honda Motor Co., Inc. and reprinted with permission)

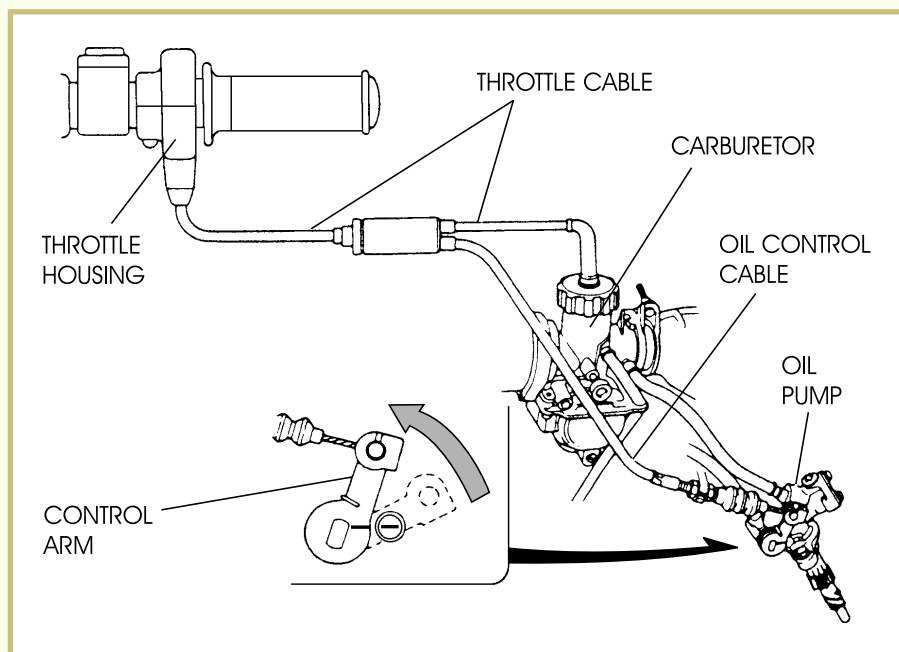

Different methods are used to indicate the oil pump lever position in relation to the carburetor throttle valve opening. Usually a punch mark on the throttle valve is aligned with a mark on the carburetor body when the pump lever is in the proper position. This is a common procedure, but you'll need to check the motorcycle or ATV service manual for further instructions on the type of pump design and recommended adjustment.

In oil injection systems, the oil storage tank must not be allowed to run dry. If this happens, or if the oil pump is removed, air enters the oil lines. Air in the system won't allow the oil to flow properly to the

components in need of lubrication. The air must be removed to ensure that proper lubrication takes place. The method used to remove air bubbles from oil lines is called *bleeding*. A common way to bleed air from the system is to allow gravity to do the job. This is done by removing the oil line located at the oil pump. After this line is removed, the oil flows out the hose, bringing the air bubbles along with it. You should allow the oil to drip into an oil pan that you've placed under the pump. How does this really work? The oil storage tank is located physically higher than the oil pump. When the oil line is removed from the pump, gravity lets the oil flow freely from the oil storage tank to the oil pump. Manufacturers suggest various methods for bleeding a system. You should follow their instructions very carefully.

Transmission Lubrication

As discussed early in this study unit, two-stroke crankcases must be sealed. Therefore, another means of lubrication must be provided for the transmission and other primary components, such as the clutch and starter. An *oil bath splash method* is used to provide lubrication for the separately sealed transmission and components (Figure 9). As the gears rotate, they pick up the lubricant and splash the oil onto other moving components in the transmission.

Special motorcycle oils including multi-grade oils and special gear oils are recommended for transmission lubrication purposes. You should use the oils recommended by the model-specific manufacturer. The amount of oil to be used is specified in the model-specific service manual.

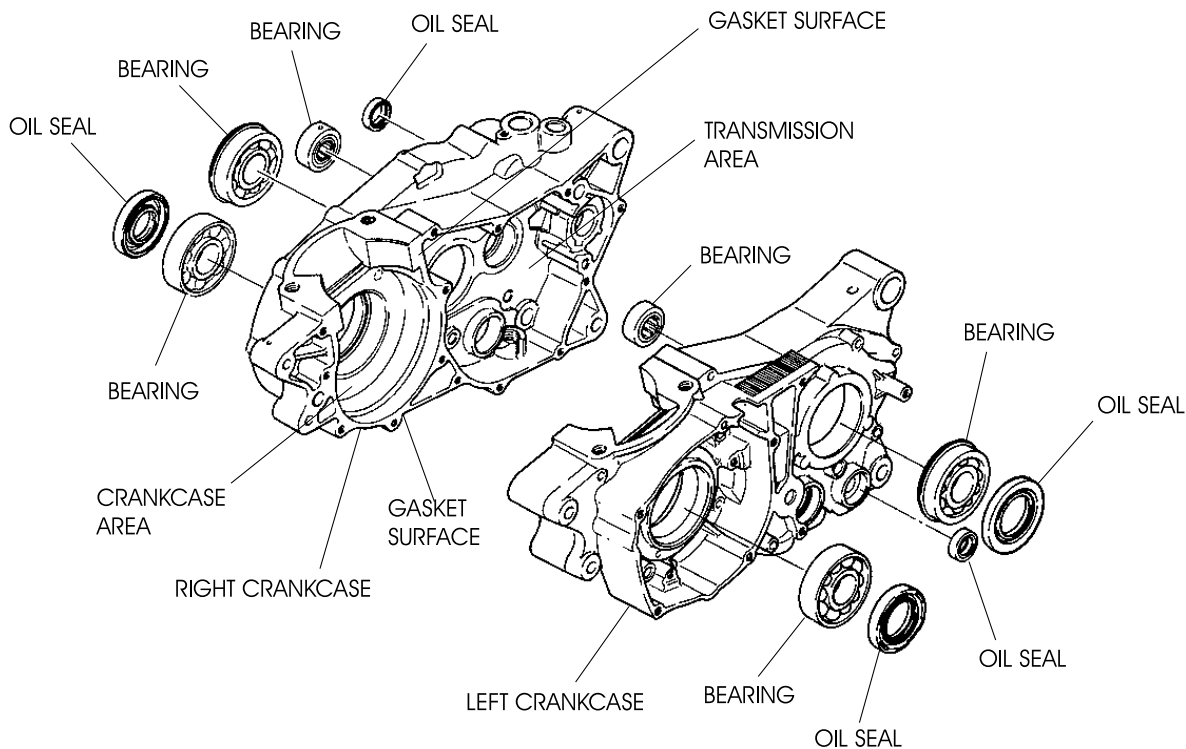
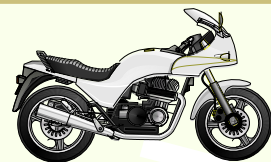

FIGURE 9—In a two-stroke engine, the transmission is separated from the crankshaft area by means of the crankcase gasket surfaces. Lubrication of the transmission is accomplished using an oil bath splash.
(Courtesy of Yamaha Motor Company)

Road Test 3



1. A two-stroke motorcycle engine's transmission is lubricated by a process known as a(n) _____.
2. What's the purpose of mixing special oil with the gasoline for use in two-stroke engines?

3. Two methods used to provide proper lubrication of a two-stroke engine are _____ and _____.
4. When premixing a two-stroke engine's gasoline and oil, what does the ratio 50:1 represent?

(Continued)

Road Test 3



5. In an oil injection lubrication system, what component is used to measure and feed the oil to the engine's internal components.

6. Name three advantages oil injection systems have over premixing gas and oil.

7. Why shouldn't you allow an oil storage tank in an oil injection system to run dry.

8. Using the steps described in this study unit, what's the correct amount of oil to premix with 1 gallon of gasoline using a 20:1 fuel-to-oil ratio.

9. *True or False?* The oil used in a two-stroke motorcycle transmission is the same oil used to lubricate the piston crankshaft and cylinder.

Check your answers with those on page 43.

FOUR-STROKE ENGINE LUBRICATION

Unlike the two-stroke engine, the lubrication system for four-stroke motorcycle and ATV engines requires the engine oil and gas to be kept separate from each other. Therefore, the four-stroke engine doesn't mix the oil with the gas, nor does the oil intentionally enter the combustion chamber. Consequently, oil isn't burned but is re-circulated throughout the engine.

The earliest four-stroke engines for motorcycles used what was known as a *total-loss* lubrication system. A total-loss system worked by using an oil tank full of oil and oil lines. The oil would drip from the oil lines onto the bearings and then be splashed onto the piston and cylinder walls by the rotating movement of the bearings. The oil was then allowed to leak out of the crankcase. In some engine designs, the oil leaking out of the crankcase was routed so that it dripped onto the chain that powered the rear wheel.

Modern four-stroke engine lubrication systems are much more sophisticated than the total-loss systems once used. They consist of the following major components:

- Engine sump (The word *sump* refers to the lowest portion of the crankcase cavity.)
- External oil storage tank, used by some four-stroke engines
- Oil pump, used to pressurize or force the oil through oil lines and passageways to the engine components that require lubrication
- Pressure relief valve, used to control excessive oil pressure

We'll discuss these components in more detail later.

Two common types of four-stroke engine lubrication systems used on motorcycles are the wet-sump and the dry-sump. A *dry-sump* engine stores its oil supply in a separate oil storage tank, while the *wet-sump* system stores its oil in the bottom of the engine's crankcase.

Dry-Sump Lubrication

The components of a typical dry-sump lubrication system are the oil storage tank, oil strainer, oil feed line, oil pump, engine oil passages, and an oil return line (Figure 10). In this system, two oil pumps are typically used. One pump acts as an oil pressure feed; the other is an oil return pump. Oil in the oil storage tank is gravity-fed to the pressure feed side of the oil pump. The oil strainer keeps relatively large pieces of dirt and debris from entering the feed line. The pump then forces oil, under pressure, through oil passages in the engine. This lubricates the moving internal engine components, which would otherwise be damaged by the heat created by friction. Oil that's thrown off the pressure-fed parts lubricates other internal engine components using the splash lubrication method. Finally, the excess oil collects in the sump and is returned to the oil storage tank by the oil return pump.

One advantage of the dry-sump lubrication system in four-stroke engines is that the oil has a better place to cool by being stored in a separate storage tank away from the hot engine. An antileak valve prevents the oil in the storage tank from leaking back into the sump. What would happen if the antileak valve were to malfunction? Engine crankcases aren't designed to contain large amounts of oil. The oil in the storage tank would fill the engine sump, causing the engine to smoke excessively. Such smoking could possibly foul the spark plugs.

FIGURE 10—A dry-sump lubrication system uses a separate oil storage tank and typically uses two oil pumps. (Copyright by American Honda Motor Co., Inc. and reprinted with permission)

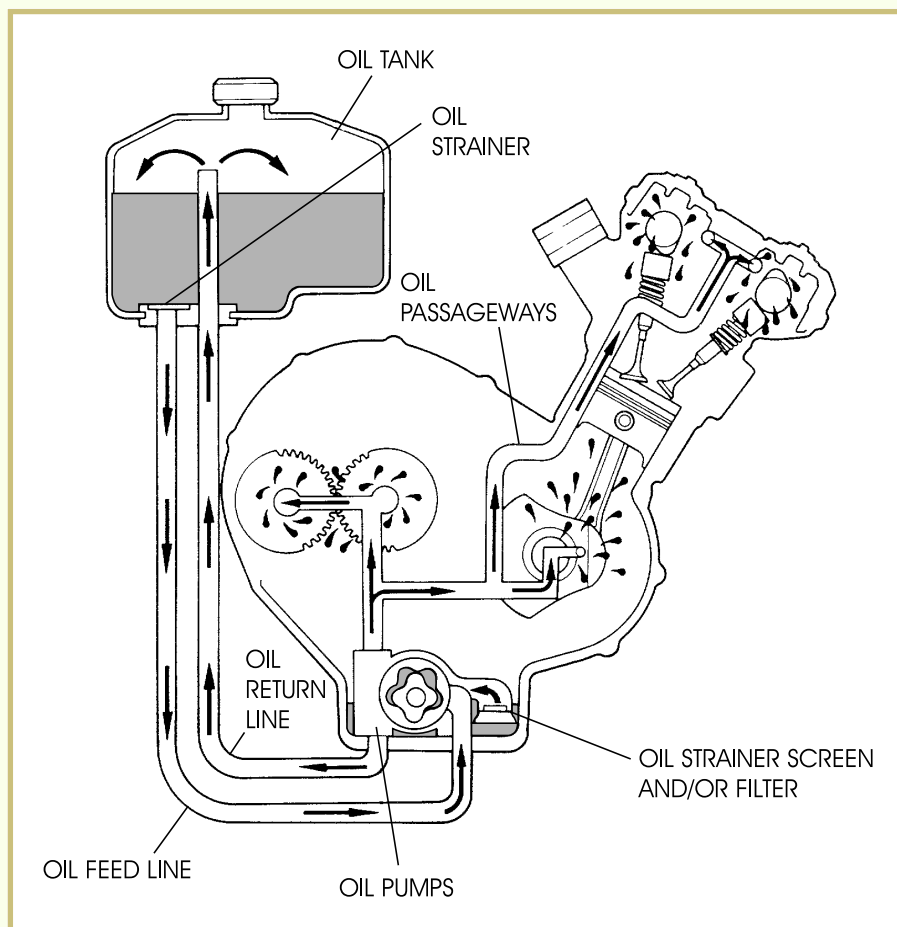

Wet-Sump Lubrication

Wet-sump lubrication systems differ from dry-sump lubrication systems in two major ways. First, in wet-sump lubrication systems, oil is stored in the engine crankcase, not in a separate oil tank (Figure 11). Second, only one oil pump is used in wet-sump four-stroke engines. Similarly to dry-sump lubrication systems, oil is pressure-fed to all areas in need of lubrication. Examples of areas needing lubrication are cam bearing areas, pistons and cylinders, and main crankshaft bearing areas. The oil that's pressure-fed to these areas is thrown off the rotating components and drained back to the sump, where the oil pump picks it up once again and re-circulates it to those high-friction areas that need lubrication.

One advantage of a four-stroke wet-sump lubrication system is that it has fewer components and no external oil lines carrying the major supply of engine oil. This results in the wet-sump system being less prone to oil leaks. Another advantage of wet-sump systems is a lower center of gravity, because the engine oil is contained in the bottom of the engine. This helps to improve the handling of the motorcycle.

FIGURE 11—A wet-sump lubrication system stores oil in the engine crankcase. Typically, this system uses only one oil pump. (Copyright by American Honda Motor Co., Inc. and reprinted with permission)

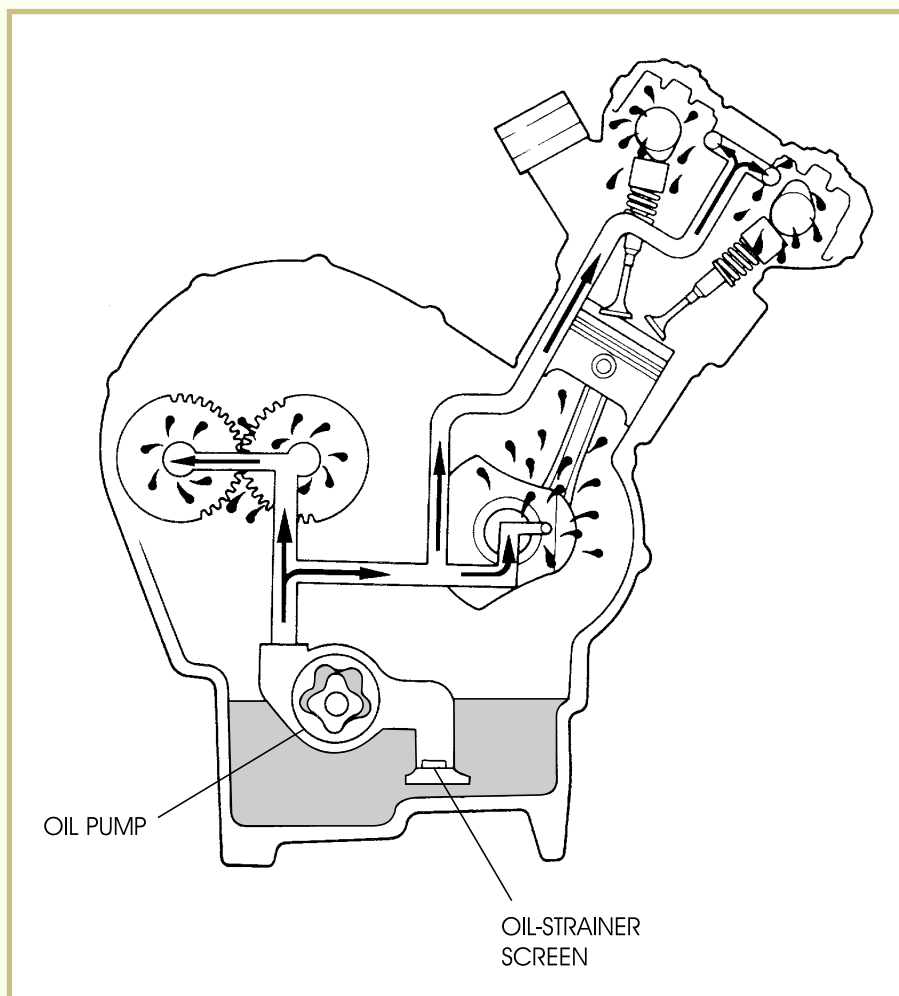

Oil Pumps

Four-stroke motorcycle wet-sump or dry-sump engines may use one of three basic types of oil pumps. They are the gear type, plunger type, and the most commonly used type—the trochoid or rotor type. It's important to understand the operation of each type.

Gear-Type Oil Pumps

The *gear-type oil pump* consists of a housing and two spur gears: a drive gear attached to the oil pump shaft and a driven gear (Figure 12). The teeth of the gears are meshed together and move oil as they rotate. As the oil is picked up at one side of the oil pump, it's forced to the other side by the gear teeth. This oil pump design produces only moderate oil volume and pressure.

FIGURE 12—Gear-Type Oil Pump

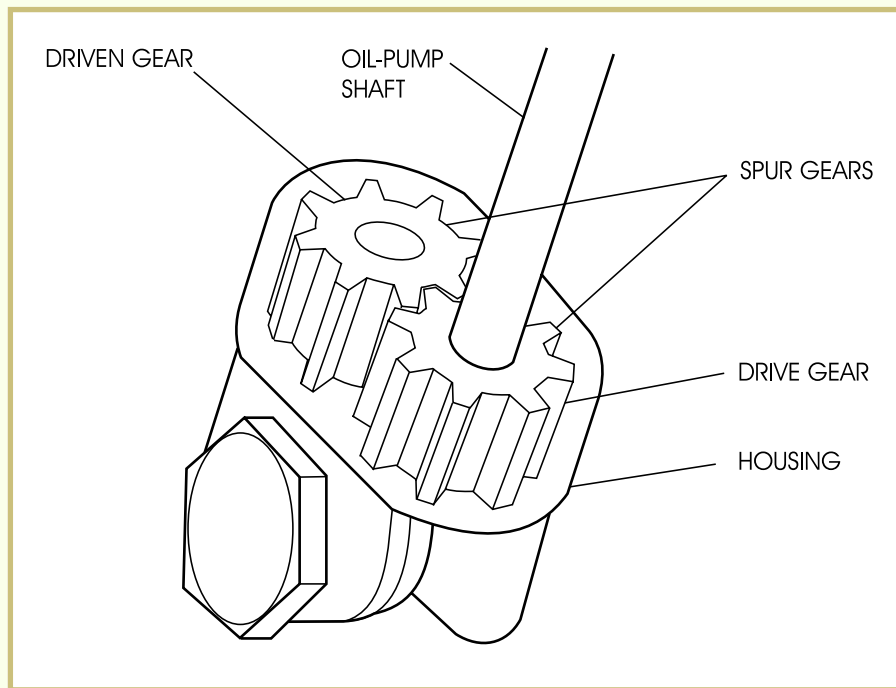

Plunger-Type Oil Pumps

The *plunger-type oil pump* consists of a set of check valves, a piston, and a cylinder (Figure 13). When the piston moves up in the oil pump's cylinder, oil is drawn in past the inlet check ball. As the piston moves back down the cylinder, the inlet check ball closes and oil is forced past the outlet check ball. This pump design is capable of high pressure, but produces only low-volume oil flow.

FIGURE 13—Plunger-Type Oil Pump

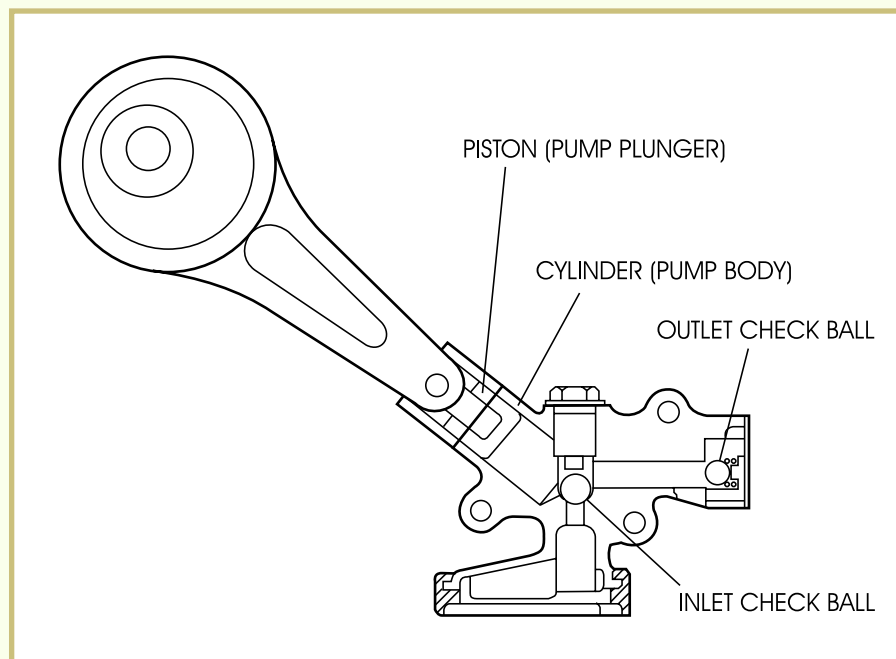

Rotor-Type Oil Pumps

The most commonly used oil pump in four-stroke motorcycle engines is the *rotor-type pump* (Figure 14). The rotor pump consists of a pair of rotors: an inner rotor and an outer rotor. The inner rotor is shaft driven, while the outer rotor is moved by the inner rotor and is free to turn in the housing. The lobes on the rotors squeeze oil through passages in the pump body. As the inner rotor rotates, oil is constantly picked up from the inlet side, transferred, and pumped through the outlet side. Oil pressure is created when the oil is squeezed between the inner and outer rotors. The rotor-type oil pump design is capable of creating both high volume and high pressure. Most of these pumps have a spring-loaded valve used to bleed off excessive oil after the oil pressure reaches a predetermined level.

FIGURE 14—The rotor-type oil pump is the most widely used pump in the modern four-stroke motorcycle engine. (Courtesy Kawasaki Motor Corp., U.S.A.)

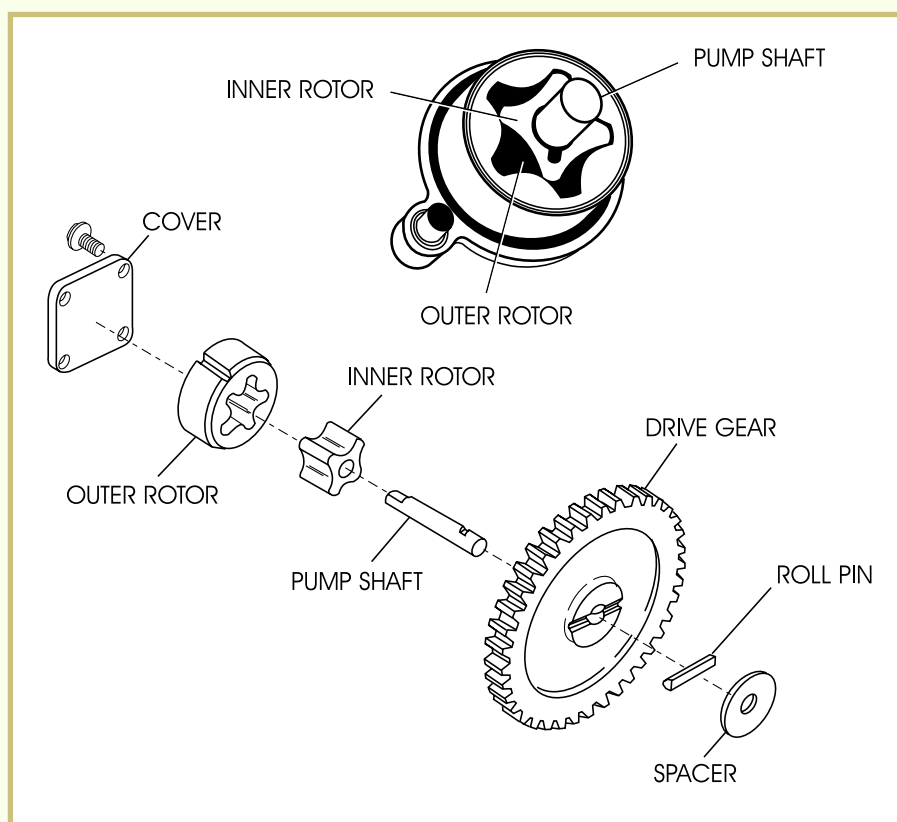

Oil Pressure Relief Valve

The *oil pressure relief valve* is usually located near the oil pump (Figure 15). Its purpose is to prevent excessive oil pressure from building up by bleeding excessive oil back into the crankcase. The oil pressure relief valve operates during cold starts when the oil is thick or when the engine is run at excessive rpms.

FIGURE 15—Oil Pressure Relief Valve Components
(Copyright by American Honda Motor Co., Inc. and reprinted with permission)

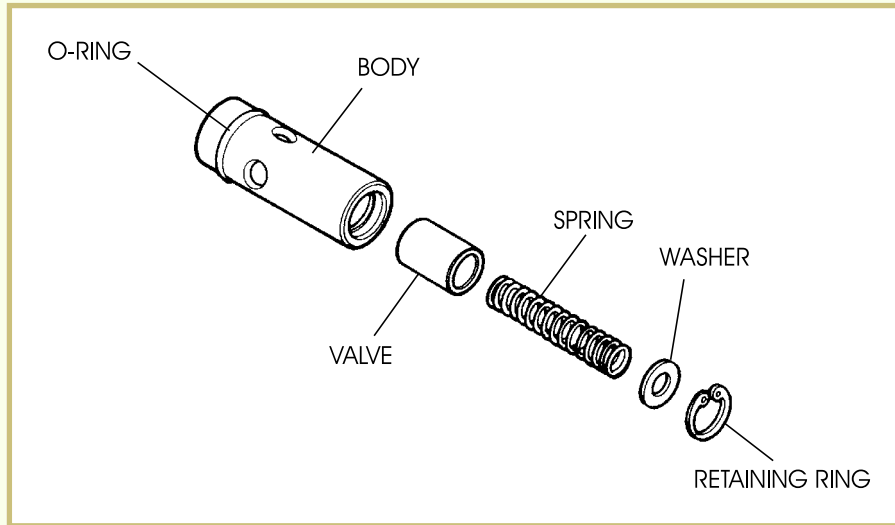

Oil Filters

Four types of oil filters are used on four-stroke engines.

- The *paper oil filter* uses treated pleated paper; it may be a spin-on type or a cartridge type (Figure 16).
- The *fiber oil filter* traps contaminants throughout the filter, not just on the surface area. This type of filter was used for many years in dry-sump lubrication systems, but is no longer popular.
- The *screen or wire-mesh oil filter* traps large contaminants.
- The *centrifugal oil filter* spins the oil at crankshaft speed. Because dirty oil is heavier, it's trapped within a canister that surrounds the filter assembly.

Both the screen and centrifugal types of oil filters are found primarily on smaller four-stroke motorcycle engines.

FIGURE 16—A Paper-Style Cartridge Oil Filter, with Components that Complete the Oil Filter Assembly
(Copyright by American Honda Motor Co., Inc. and reprinted with permission)

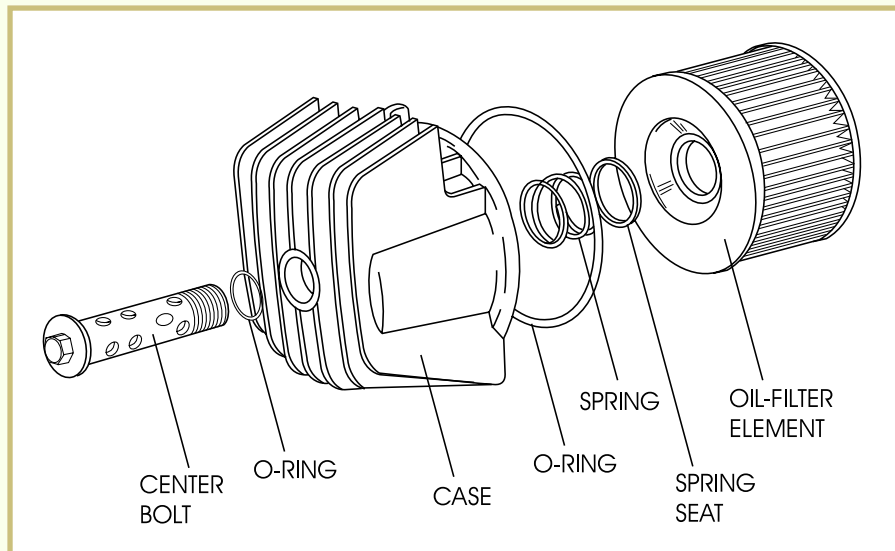

Oil Bypass Valve

Most spin-on oil filters and oil filter bolts include an *oil bypass valve*. When the oil flow through the filter is restricted from an excessively dirty filter or extremely cold running conditions, the valve allows the oil to bypass the filter, thus providing essential lubrication to critical engine components. Notice that the oil bypass valve illustrated in [Figure 17](#) has a bolt, which contains a spring and a ball. When pressure is excessive in the oil filter housing, the ball pushes the spring, allowing the oil to bypass the filter. Unfiltered oil is better than no oil at all!

FIGURE 17—Oil Bypass Valve and Its Components (Courtesy Kawasaki Motor Corp., U.S.A.)

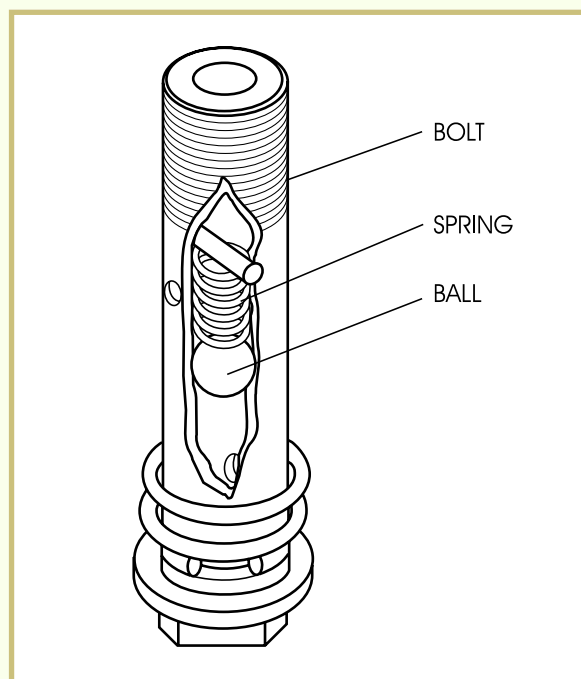

Oil Passages

The flow of oil for a typical four-stroke motorcycle is shown in [Figure 18](#). The illustration provides evidence of the many different duties performed by the oil used for lubrication in this engine. *Oil passages*, or *pipes*, deliver the oil from the pump to the crankcase, camshaft, valves, and all other internal parts in need of lubrication. Most crankcases have holes machined into them to supply oil to the crankshaft and transmission shafts. Some models use an external oil line to deliver oil to the top end, while some four-stroke engines simply pump oil up one or more cylinder studs. These studs are sealed with O-rings, which must be replaced any time the engine is disassembled.

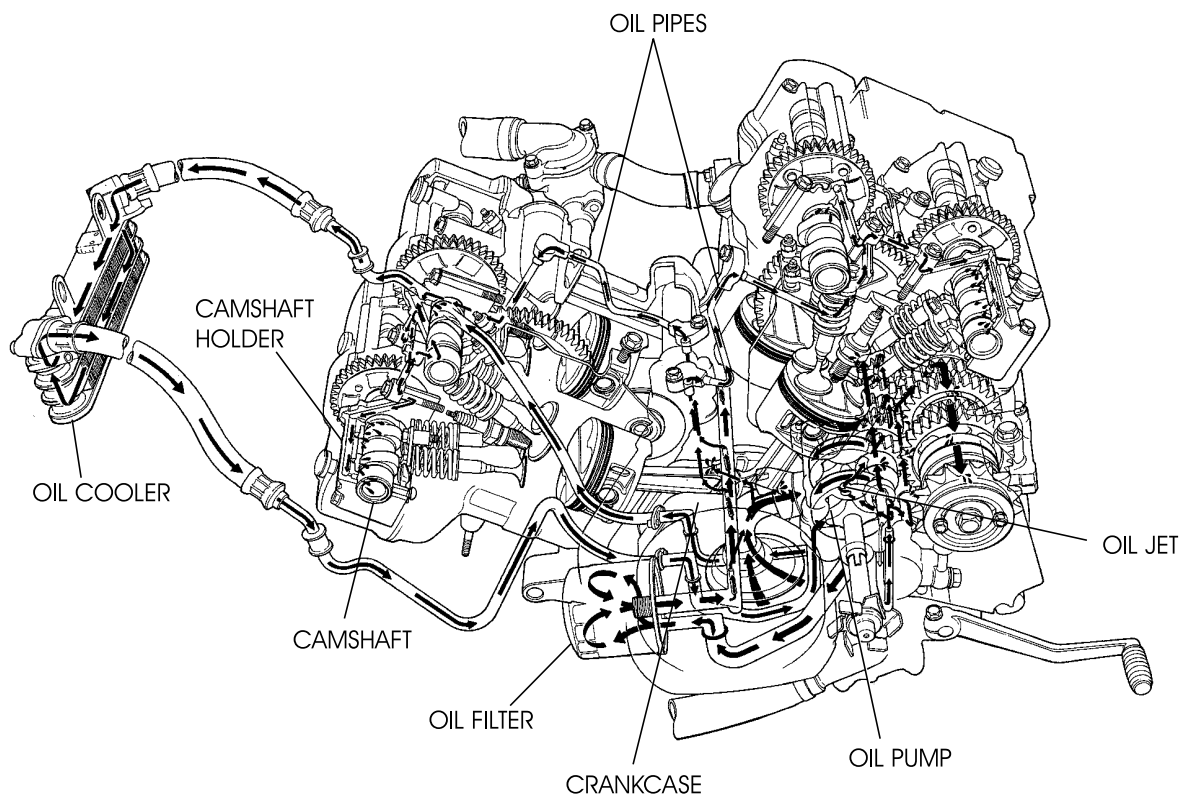
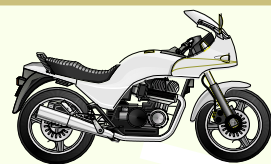

FIGURE 18—The four-stroke engine uses many paths for the oil to get to its numerous lubrication points.
 (Copyright by American Honda Motor Co., Inc. and reprinted with permission)

Road Test 4



1. To what does the word *sump* refer?

2. Which type of oil pump is most commonly used on four-stroke motorcycle engines?

3. What are the two types of paper oil filters found in four-stroke lubrication systems?

4. Which type of oil filter spins the oil at crankshaft speed, trapping contamination in a canister?

(Continued)

Road Test 4

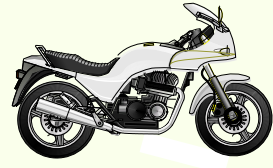

5. What component prevents excessive oil pressure from building in a four-stroke lubrication system?
6. *True or False?* The wet-sump lubrication system stores its oil in the crankcase.

Check your answers with those on page 43.

COOLING SYSTEMS

Motorcycle engine cooling systems assist in the removal of excess heat produced by the engine. They're designed to allow the engine to operate at a temperature predetermined by the manufacturer. There are three types of cooling systems found on motorcycle engines: internal-oil cooling, air cooling, and liquid (coolant) cooling.

Internal-Oil Cooling

All motorcycle engines use *internal-oil cooling* in their engine designs. The components of internal cooling are the oil, oil coolers (used on some motorcycles), oil pumps, and oil filters, along with the oil passages and oil lines. As the oil is circulated throughout the engine, heat is transferred to the oil from the engine components with which the oil has come in contact.

Air Cooling

Air-cooled engine designs use fins on the cylinder head and cylinder to dissipate heat to the surrounding air. There are two air-cooling methods used on motorcycles:

- *Open-draft cooling* uses the movement of the motorcycle to force air over the fins, removing the excess heat from the engine (Figure 19).
- *Forced-draft cooling* uses an engine-driven fan, which draws air through ductwork called *shrouds* (Figure 20). Shrouds surround the cylinder and the cylinder head.

FIGURE 19—The open-draft method of air cooling uses the flow of air over and across the cylinder and cylinder head to keep the engine cool when in motion.

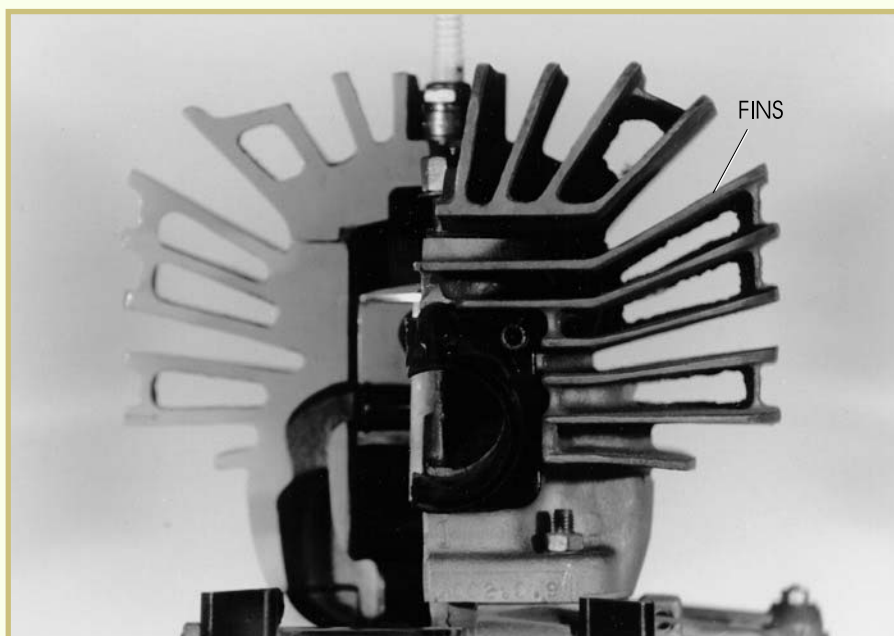
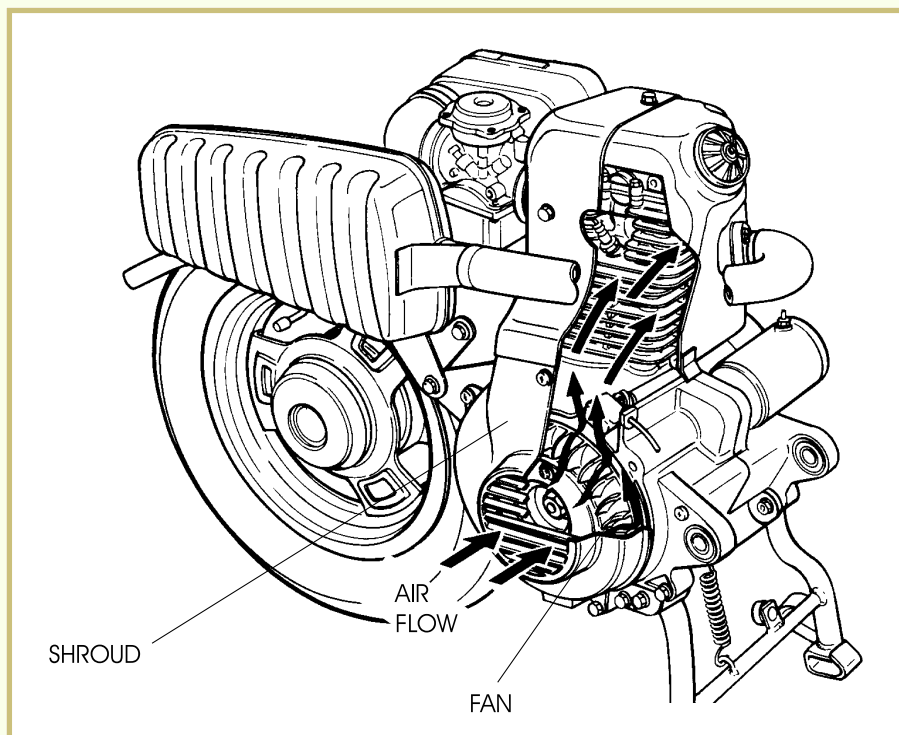

FIGURE 20—The forced-draft method of air cooling uses an engine-driven fan to draw air through the shrouds.



Liquid Cooling

Although creating a slightly heavier motorcycle because of the extra needed components, *liquid cooling* is extremely popular with motorcycles being built today. A liquid-cooled engine gives the motorcycle manufacturer the ability to better control the engine temperature. Liquid-cooled motorcycle engines contain various components,

which are described in the following sections. Components include the

- Water pump
- Radiator
- Thermostat
- Radiator cap
- Coolant
- Radiator fan

Typical liquid cooling system flow paths are illustrated in [Figure 21](#).

Water Pump

The liquid-cooled engine's *water pump*, whose purpose is to circulate the coolant, is driven by the engine ([Figure 22](#)). It draws coolant through its inlet pipe and discharges it into the engine's water jackets. The water pump assures that the coolant is sent to all needed areas in a uniform manner. The pump consists of a pump shaft, impeller, bearings, mechanical seal, oil seal, and a housing.

The water pump housing includes a drain hole, known as a *telltale hole*. Coolant leaking out the telltale hole is an indication that the mechanical seal is leaking ([Figure 23](#)). This is the most common problem found in a motorcycle liquid cooling system. The water pump may be rebuilt, but in most cases, the pump is replaced if the mechanical seal fails. If engine oil appears to be leaking out the telltale hole, the oil seal is at fault. The oil seal is normally replaceable and doesn't require replacement of the water pump.

Radiator

The *radiator* is a cooling device that allows for rapid heat removal. The radiator cools the moving liquid inside the cooling system as it's pumped through the engine. A radiator is also known as a *heat exchanger*. The radiator consists of small tubes or passages surrounded by very thin cooling fins ([Figure 24](#)). On most motorcycles, the radiator is constructed of aluminum alloy. As the coolant temperature rises, the coolant expands. Most radiators also include a reservoir, or reserve tank, which allows expansion and contraction of the coolant. If a radiator is damaged, it normally needs to be replaced. Although it's possible to repair radiators on motorcycles, the cost to repair them may be higher than the cost to replace them!

FIGURE 21—The liquid-cooled engine is a popular choice for motorcycle engine designs. (Copyright by American Honda Motor Co., Inc. and reprinted with permission)

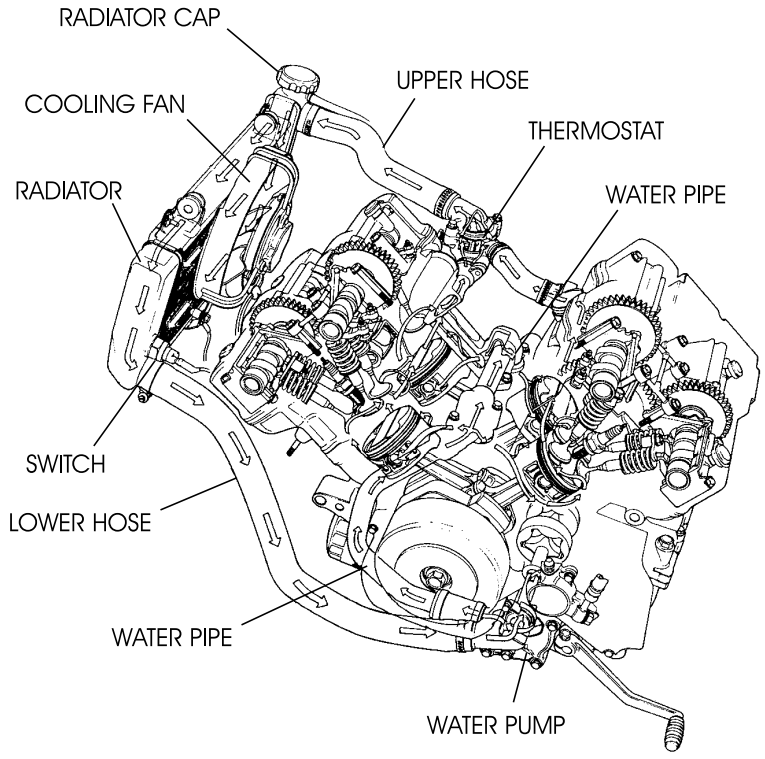

TYPICAL 4-STROKE ENGINE COOLANT FLOW PATH

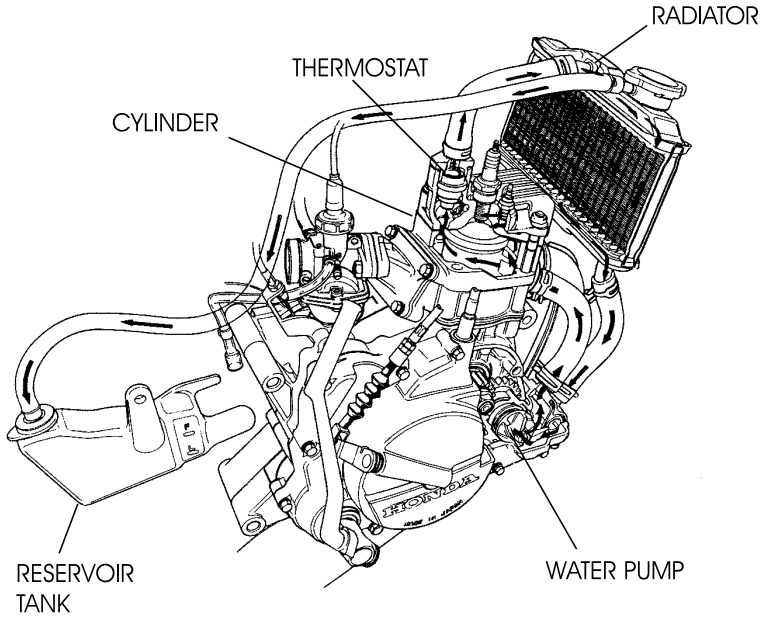

TYPICAL 2-STROKE ENGINE COOLANT FLOW PATH

FIGURE 22—A Typical Water Pump Assembly (Copyright by American Honda Motor Co., Inc. and reprinted with permission)

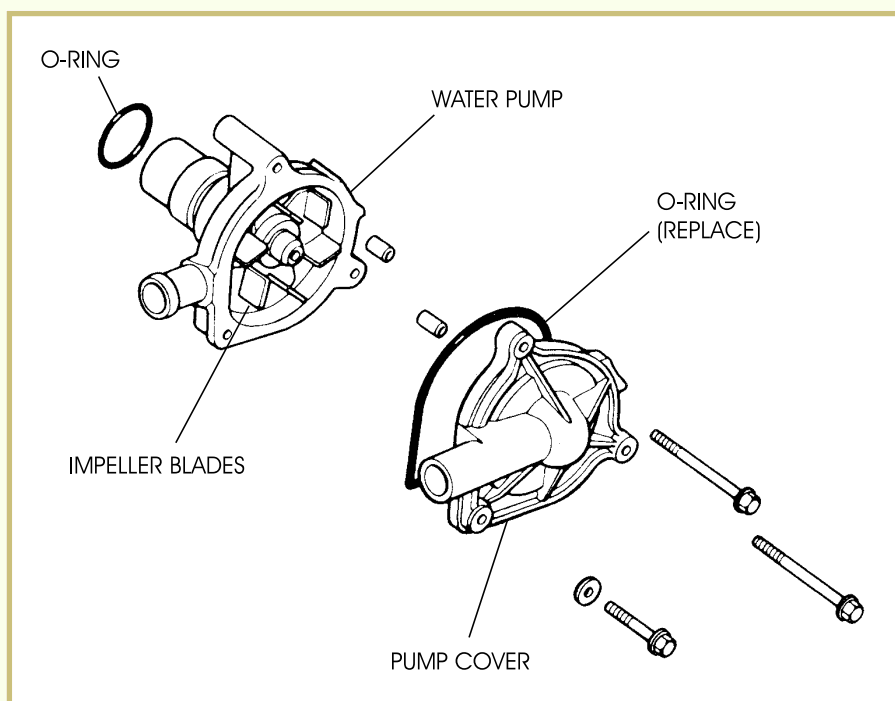
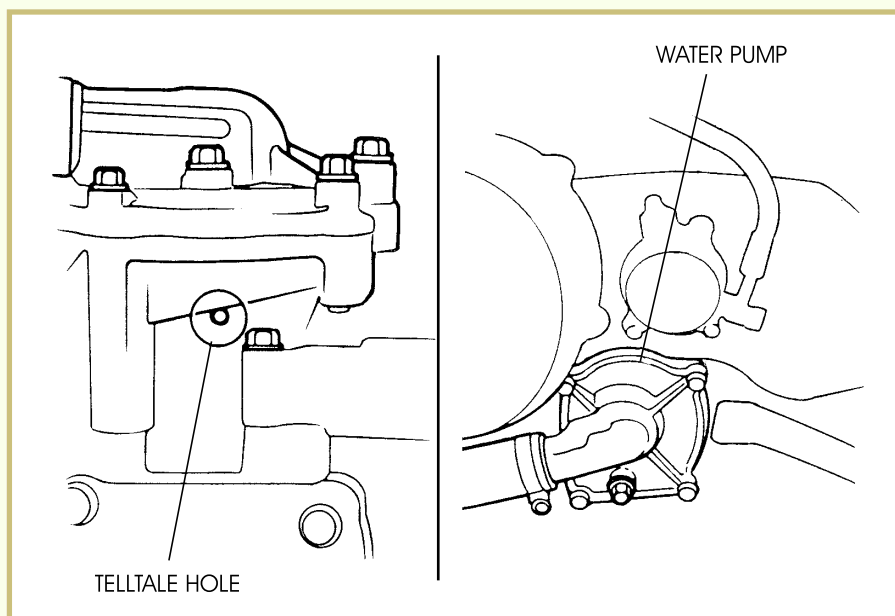

FIGURE 23—The telltale hole in a water pump gives warning when the pump needs repair or replacement. (Copyright by American Honda Motor Co., Inc. and reprinted with permission)



Thermostat

The *thermostat* is a temperature-sensitive flow valve. Its purpose is to provide a quicker engine warm-up time. It also ensures that the engine operates at a predetermined temperature. When the engine is cold, the thermostat is in the closed position, as seen in [Figure 25](#). This allows the coolant to flow through the engine only and not into the radiator. When the engine reaches its predetermined operating temperature, the thermostat opens, permitting the coolant to flow through the radiator, as seen again in [Figure 25](#).

FIGURE 24—In a radiator, air fins cool the coolant as it flows through the water tubes.

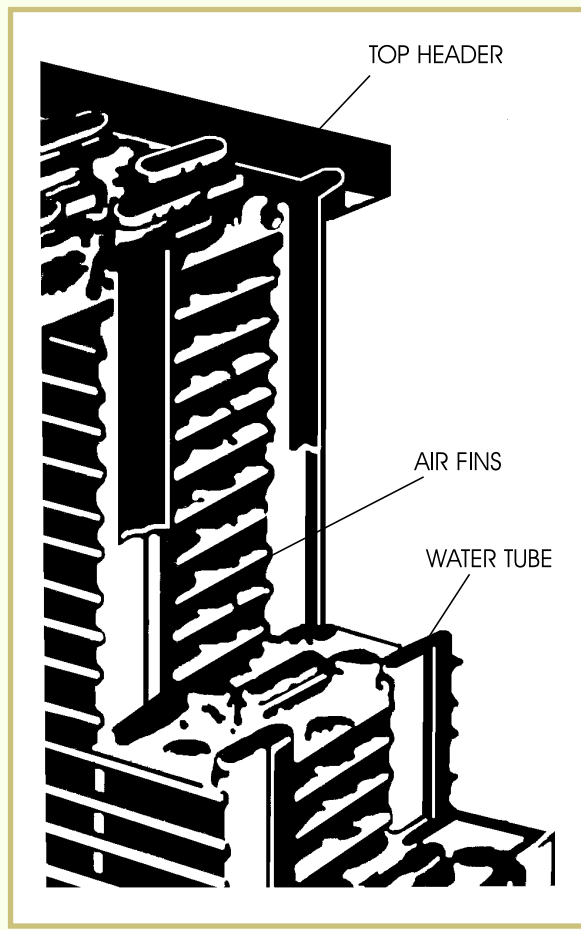
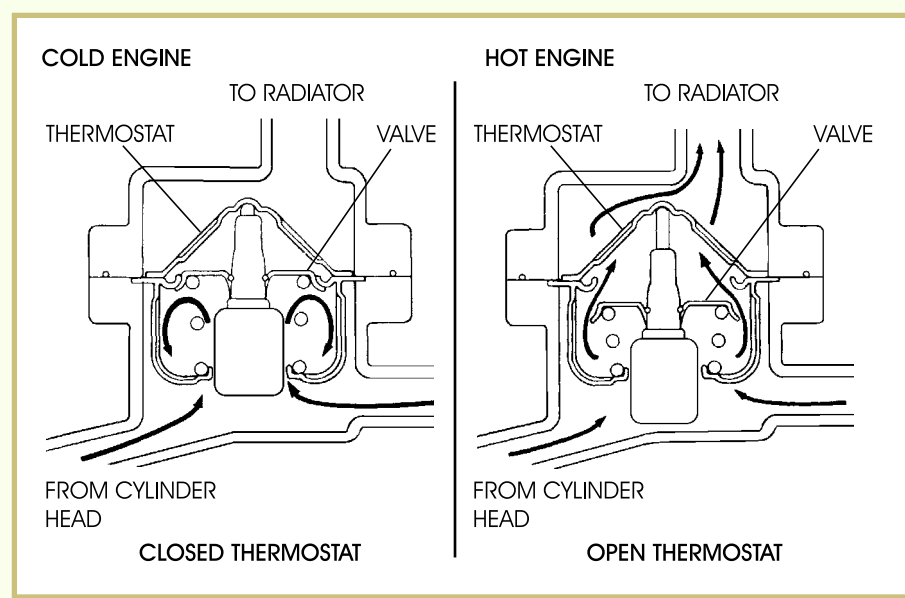

FIGURE 25—The thermostat remains closed when the engine is cold, keeping the flow of coolant from reaching the radiator. This provides for quicker engine warm-ups. When the engine reaches a predetermined operating temperature, the thermostat opens, allowing coolant to pass through the radiator. (Copyright by American Honda Motor Co., Inc. and reprinted with permission)



The thermostat may be tested by suspending it in heated water and checking the temperature with a thermometer when it opens. If the thermostat doesn't open at the correct temperature given by the manufacturer, doesn't open at all, or doesn't close, it must be replaced.

Radiator cap

The *radiator cap* seals the cooling system from the outside atmosphere. It's also used to limit the cooling system's operating pressure. The boiling point of a liquid is increased by 3° Fahrenheit for each 1 psi of pressure. Motorcycle radiator caps are usually designed to hold 12–17 psi of pressure. They may be tested using a pressure tester (Figure 26). If the cap fails the test, it must be replaced.

FIGURE 26—A cooling-system tester can be used to perform a radiator cap pressure test. (Copyright by American Honda Motor Co., Inc. and reprinted with permission)

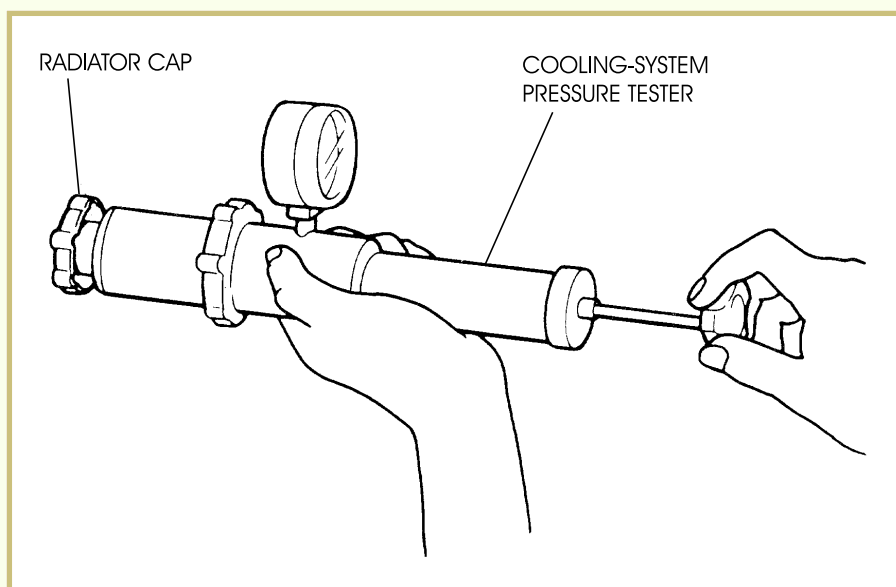

Coolant

Coolant for a liquid-cooled motorcycle usually consists of a 50/50 mixture of distilled water and antifreeze (ethylene or propylene glycol). One part water is used for each part of antifreeze because water has much better heat transfer than pure antifreeze. For the purpose of engine protection, distilled water is better than plain tap water because it doesn't contain mineral deposits that can cause corrosion.

You must use the type of coolant recommended by the manufacturer to ensure that the engine is protected from damage due to corrosion. You should never use 100% ethylene glycol in any cooling system. Ethylene glycol is a very poor coolant when used by itself. The purpose of using antifreeze in a liquid-cooled engine is to lower the freezing point and raise the boiling point of the liquid (water). By mixing antifreeze with water in the proper proportion, antifreeze lowers the freezing point of water to less than 30° Fahrenheit. (Water normally freezes at 32° F.) At the same time, antifreeze raises the boiling point

of water to more than 225° Fahrenheit. (Water normally boils at 212° F.) Antifreeze also contains lubricants, anti-foaming additives, and corrosion inhibitors that help protect the engine. The antifreeze-and-water coolant is pumped along water jackets through the cylinder head and cylinder. The heated coolant then flows through the radiator, where heat is dissipated to the surrounding air.

Radiator Fan

The fan used with the liquid-cooled engine system helps to move air through the radiator when the motorcycle isn't in motion or when it's moving too slowly to get the correct amount of air through the radiator. The fan usually uses DC voltage to operate and is controlled by a temperature-sensitive sensor. It's designed to operate only when the engine reaches a predetermined temperature. The fan may be designed to continue running even if the motorcycle is shut off.

Liquid-Cooling System Testing

Liquid-cooled systems can be pressure-tested to check for leaks ([Figure 27](#)). *Pressure testing* verifies that the system can hold a specified pressure for a required time. Specifications for this test are available in the service manual for the specific model. If the system fails the pressure test, check the hoses, pipe connections, and the water pump installation and seal.

FIGURE 27—Cooling systems must be pressure-tested to verify that the system is operating correctly. (Copyright by American Honda Motor Co., Inc. and reprinted with permission)

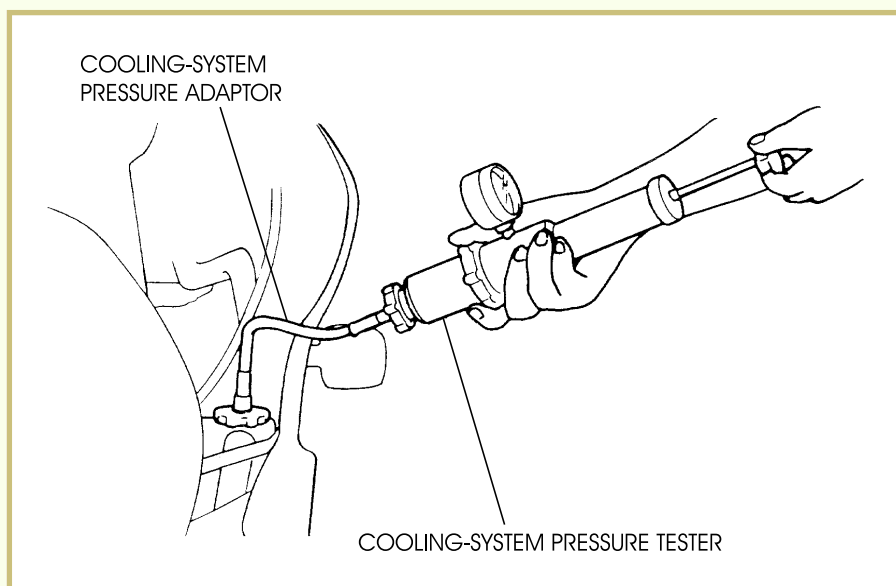

Another common test for liquid-cooled engines is a *specific-gravity test*. This test uses a *hydrometer*, which measures the weight of liquid as compared to the weight of water ([Figure 28](#)). When antifreeze is added to water, the hydrometer measures the weight change.

FIGURE 28—The hydrometer measures the specific gravity of the coolant to verify that it's correctly mixed. (Copyright by American Honda Motor Co., Inc. and reprinted with permission)

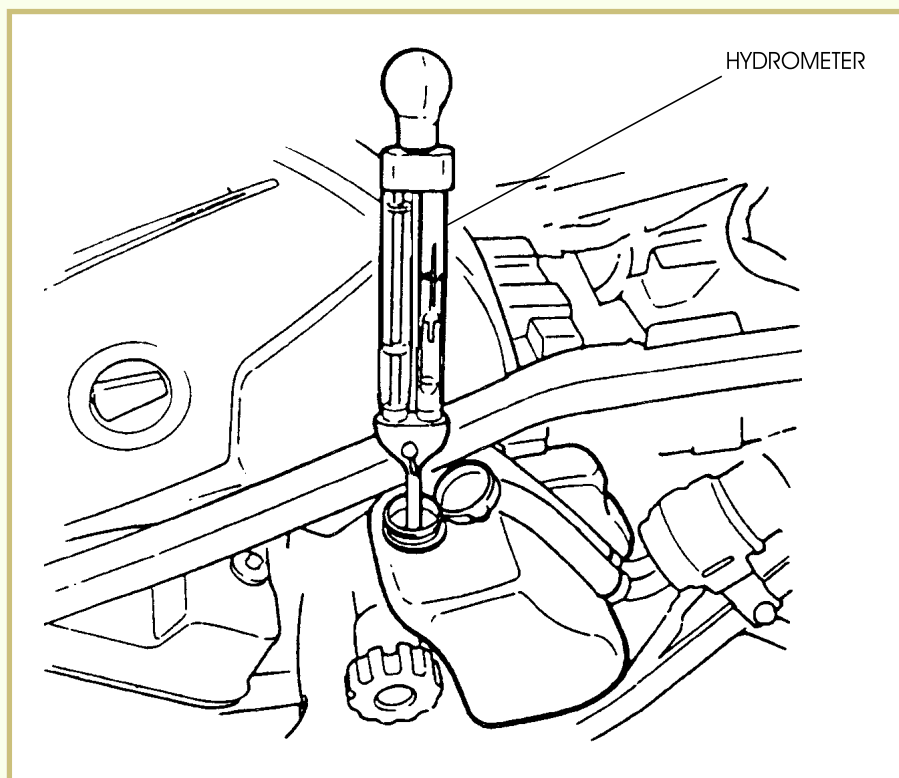

Road Test 5

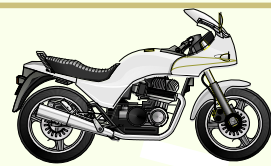

1. The three types of cooling systems found on motorcycles are _____, _____, and _____.
2. Of the three types of cooling systems, the _____ cooling system is found in all engines.
3. The type of air-cooled engine that uses an engine-driven fan and shrouds is called a _____ system.
4. If coolant is leaking out the water pump housing drain hole, the _____ is most likely at fault.
5. The component used as a heat exchanger on a liquid-cooled engine is called the _____.
6. The _____ is a temperature-sensitive flow valve.
7. If the temperature of a liquid-cooled engine rises due to lack of movement, the _____ helps to reduce the temperature.

(Continued)

Road Test 5

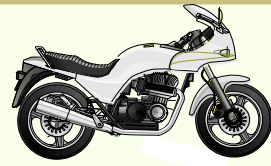

8. It's recommended that the coolant used in a liquid-cooled engine be mixed in a _____ ratio.
9. *True or False?* Ethylene glycol (antifreeze/coolant) is a poor coolant when used alone.
10. *True or False?* The thermostat slows down the warm-up time in a liquid-cooled engine.

Check your answers with those on page 44.

LUBRICATION SYSTEM MAINTENANCE

Although a future study unit covers maintenance in detail, we'll briefly cover lubrication system maintenance now to help you become familiar with it.

Two-Stroke Engine

Only minor maintenance is required with the two-stroke engine lubrication system. If you're using the premixed method of lubrication, you must ensure a correct ratio of oil to fuel. If you have an oil-injected lubrication system, you must verify that there's an adequate supply of oil in the oil tank.

Two-Stroke Transmission and Clutch

The two-stroke transmission and clutch have a separate oil drain plug, normally found on the bottom of the engine crankcase ([Figure 29](#)). It's necessary to drain and replace the oil on a regular basis as described in the appropriate owner's or service manual.

Four-Stroke Engine, Transmission, and Clutch

Most four-stroke motorcycle engines use the same oil to lubricate the engine as they use for the transmission and clutch. These engines usually have just one drain plug for removing oil from the engine crankcase ([Figure 30](#)). In most cases, there's also an oil filter that needs to be replaced at the same time the engine oil is changed. Changing the oil filter is as important as changing the engine oil because the filter contains most of the dirt and contaminants from the engine.

FIGURE 29—Draining Oil from a Two-Stroke Engine Crankcase (Copyright by American Honda Motor Co., Inc. and reprinted with permission)

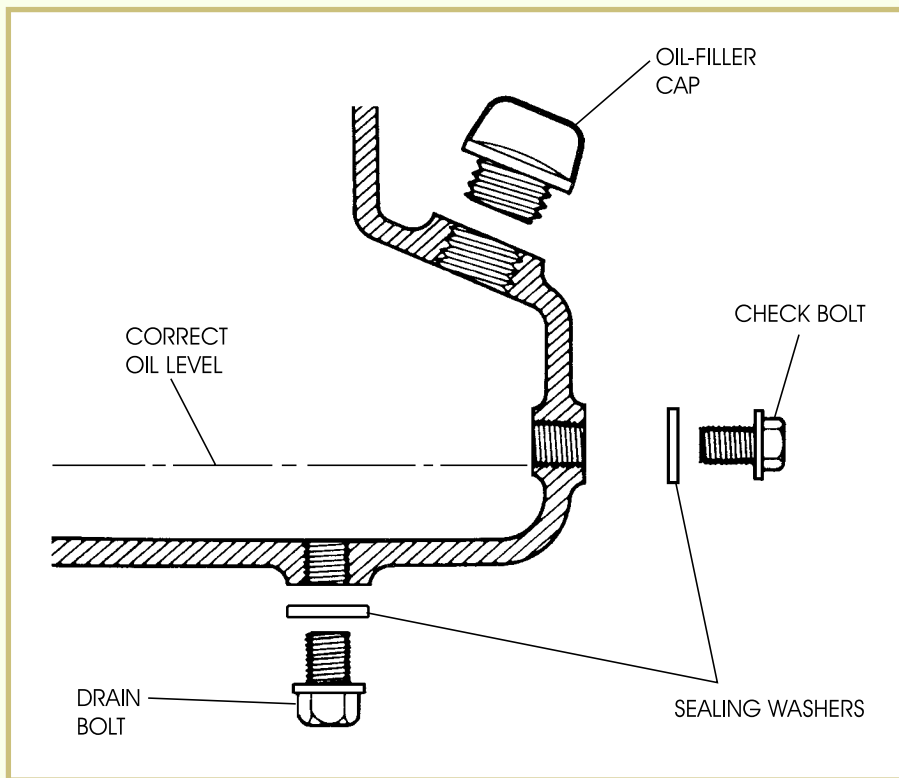
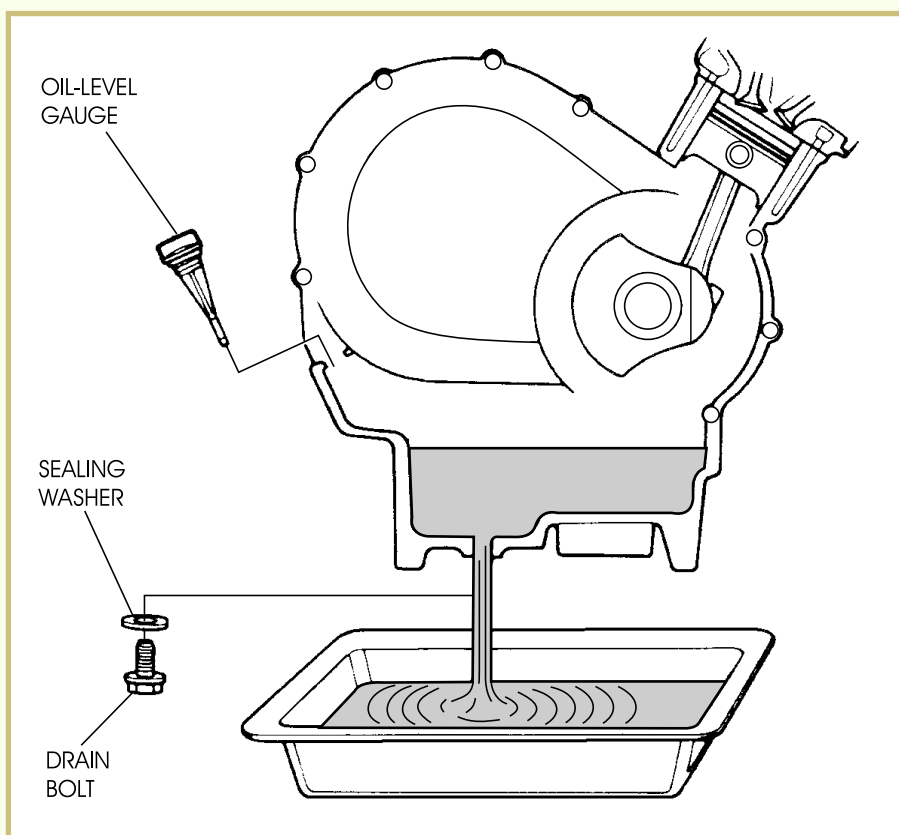

FIGURE 30—Draining Oil from a Four-Stroke Engine Crankcase (Copyright by American Honda Motor Co., Inc. and reprinted with permission)



Other Components

While the engine must have a source of oil to operate properly, lubrication of other parts of the motorcycle is equally important. This is usually accomplished by applying grease or oil at regular time intervals to points of wear. Note that the grease used for wheel bearing lubrication is different from grease used on other chassis components. Use caution to not over-lubricate components, as this may cause dirt to collect.

The component outside the engine that requires the most attention (as far as lubrication is concerned) is the chain. This is especially true for off-road motorcycles and ATVs. Dirty conditions cause considerable wear to the chain and sprockets. [Figure 31](#) points out lubrication points on a typical ATV. Lubrication points are similar on motorcycles.

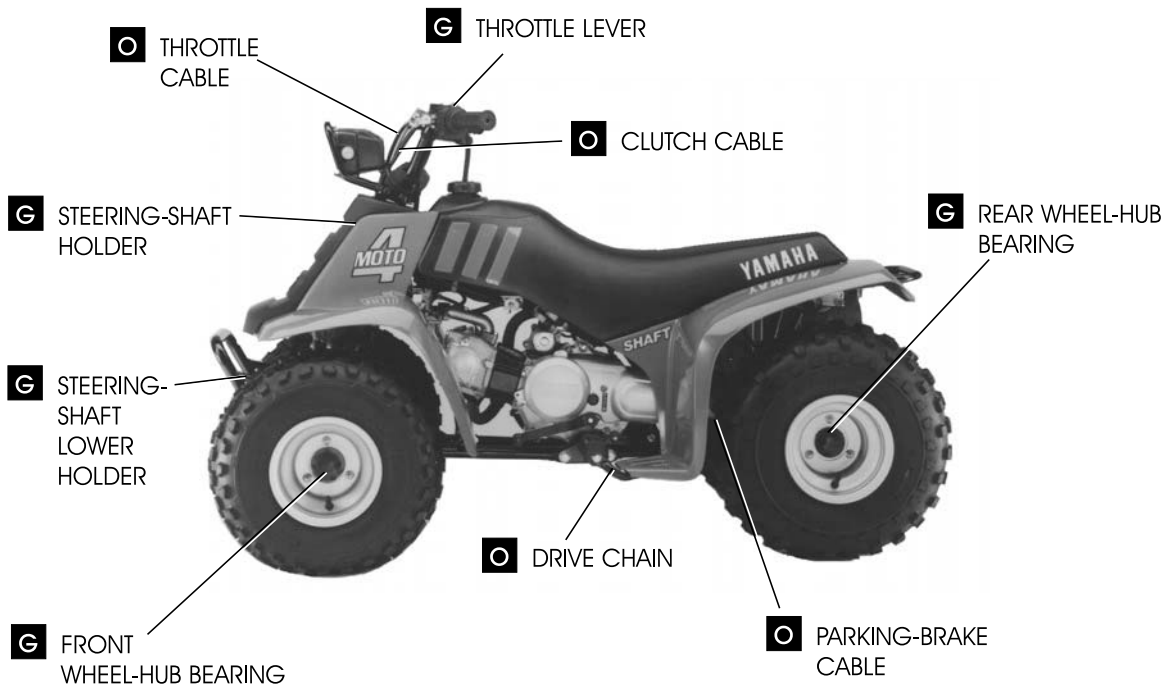

FIGURE 31—Typical lubrication points for an ATV are illustrated in this figure. Areas marked with **O** require oil lubrication; areas marked with **G** require grease lubrication. (Courtesy of Yamaha Motor Company)

Road Test Answers

1

1. Cooling, cleaning, sealing, lubricating
2. petroleum based, synthetic based, petroleum/synthetic blend
3. Fractional distillation
4. Viscosity
5. additives
6. American Petroleum Institute
7. Society of Automotive Engineers
8. An oil that's suitable for use over a wide range of conditions
9. Grease
10. 0 degrees Fahrenheit

2

1. To help reduce the buildup of friction
2. Ball, roller, tapered roller, needle
3. roller
4. tapered roller
5. plain
6. To keep lubricants in and contaminants out
7. Plain
8. Ball and roller bearings

3

1. oil bath splash
2. To lubricate the internal engine components
3. premix, oil injection
4. 50 parts of fuel to 1 part of oil
5. Oil pump
6. The rider doesn't have to mix the fuel and oil, less oil consumption, provides the proper amount of oil to moving parts over a range of engine speeds
7. Air will enter the system, which won't allow proper oil flow and may cause an engine failure.
8. 6.4 ounces
9. False

4

1. The lowest portion of the crankcase cavity
2. Rotor type
3. Cartridge and spin-on
4. Centrifugal
5. Oil pressure relief valve
6. True

5

1. internal-oil, air, liquid
2. internal-oil
3. forced-air
4. mechanical seal
5. radiator
6. thermostat
7. fan
8. 50/50 or 1:1
9. True
10. False

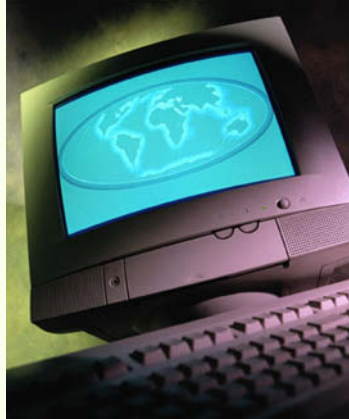

ONLINE EXAMINATION

For the online exam, you must use this

EXAMINATION NUMBER:

03300600

When you're confident that you've mastered the material in your studies, you can complete your examination online. Follow these instructions:

1. Write down the eight-digit examination number shown in the box above.
2. Click the **Back** button on your browser.
3. Click the **Take an Exam** button near the top of the screen.
4. Type in the eight-digit examination number.